

Drawing Portfolio of Vernacular Furniture : Punjab

as part of the Vernacular Furniture of North West India Project

DICRC

Design Innovation and
Craft Resource Centre
(DICRC), CEPT University,
Ahmedabad, India.

SADACC
TRUST
N O R W I C H
EST. 2010

South Asian Decorative
Arts and Crafts Collection
Trust (SADACC),
Norwich, UK.

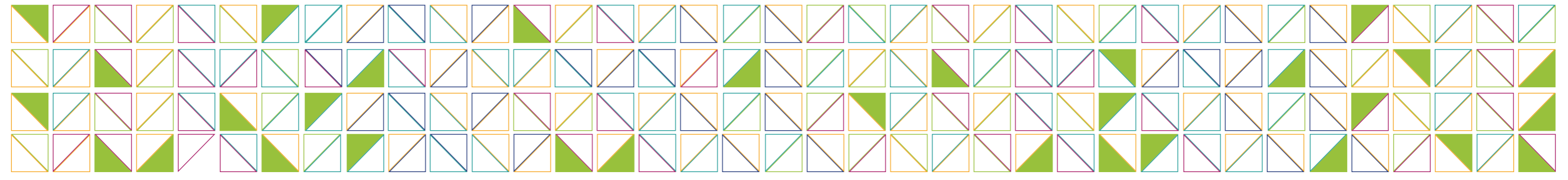

Drawing Portfolio of Vernacular Furniture : Punjab

This Drawing Portfolio is one of the outputs of the project 'Vernacular Furniture of North-West India', an international collaborative research project between the Design Innovation and Craft Resource Centre (DICRC), CRDF, CEPT University, India, and the South Asian Decorative Art and Crafts Collection Trust (SADACC), UK. The project is generously funded by SADACC. The Portfolio was prepared as part of the third phase of the project in Punjab. More information on the vernacular furniture of Punjab can be found in the publication, *Catalogue of Vernacular Furniture: Punjab* by Rishav Jain, Mansi S Rao, Ben Cartwright and Abhishek Ruikar. The research will also be presented in a forthcoming book on the Vernacular Furniture of Punjab and Haryana.



Project envisioned by:

Dr. Philip Millward and Jeannie Millward, Founders & Trustees, SADACC Trust

Jay Thakkar, Associate Professor, Faculty of Design, Executive Director & Co-founder, DICRC, CRDF, CEPT University.

Team:

Project Lead: Rishav Jain

Drawing Lead: Daksh Dev, Isha Bodawala

Drawing Advisor: Kireet Patel

Drawing Supervisors: Abhishek Ruikar, Radha Devpura

Publication Design: Rishav Jain

Photographs by DICRC and SADACC team unless specified otherwise.

All basemaps are generated using Mapbox, OpenStreetMap.

The contents of this Portfolio are available as open source resources. This may be used for research and educational purposes with due credit given to the creators and organisations.

The project team and organisations have made every effort, based on the findings of a detailed field survey and by consulting and referencing relevant sources, to ensure, to the best of their ability, that the contents of this Drawing Portfolio are free of error, defamation and copyright infringement. The contents of this Drawing Portfolio unless specified otherwise, are the opinions and findings of the team.

Other publications in the series:

Drawing Portfolios:

Drawing Portfolio of Vernacular Furniture: Gujarat

Drawing Portfolio of Vernacular Furniture: Rajasthan

Drawing Portfolio of Vernacular Furniture: Haryana

Catalogues:

Catalogue of Vernacular Furniture: Gujarat

Catalogue of Vernacular Furniture: Rajasthan

Catalogue of Vernacular Furniture: Punjab

Catalogue of Vernacular Furniture: Haryana

Books:

Sahaj: Vernacular Furniture of Gujarat

Anaikya: Vernacular Furniture of Rajasthan

Published by Design Innovation and Craft Resource Centre (DICRC), CRDF, CEPT University, Ahmedabad-380009 Gujarat, India.

Contents

About the portfolio	04
Categories	05
Furniture typology	06

aasan 07

bench - *takhtposh*
chair - *kursi*
low chair - *pidha*
floor seat - *mudha*
low seat - *parada*
stool - *pidhi*
stool - *mudha*
chair - *mudha*
swing - *peengh*

manch 25

bed - *palang*
charpoy - *manja*
cradle - *panghuda*

manjush 32

cabinet - *sandook*
chest - *peti*
chest - *peti almari*
chest - *peti*
granary - *padola*
hanger - *tangna*
alcove - *almari*
in-built cabinet - *almari*
lamp holder - *dyut*
larder - *chowki*
larder - *jaali*
shelf - *kans*
wall niche - *aliya*
wall peg - *killi*
water pitcher storage -
khadvanja

sapaat 79

low surface - *chowki*
low surface - *tarpai*
merchant's desk - *galla*

Collaborators	87
Acknowledgements	88

About

Drawing Portfolio

Drawing Portfolio of Vernacular Furniture: Punjab is a collection of technical drawings of 33 vernacular furniture pieces from Punjab. It is one of the outputs of the Vernacular Furniture of North-West India project. The project uses three main mediums to represent the findings of the research - text, photographs and drawings. The text and photographs provide an insight into anthropological aspects such as location, community, landscape and the social roles of the vernacular furniture pieces in their everyday or ceremonial contexts. Drawings, on the other hand, act as a tool to understand the structural complexity and dexterity of making of vernacular furniture.

This portfolio highlights the role of drawings in studying and representing the ingenuity of craft techniques used in the making of vernacular furniture. Each item of vernacular furniture recorded during fieldwork has unique features, style and at times deformity, owing to a bespoke approach employed by the craftspeople in response to materials and equipment available in the region. The process of making drawings is a form of inquiry into technical construction of a furniture piece. Most technical details are not visible when furniture is in use, or when interaction with the furniture is limited. In many cases, a response to this mode of inquiry leads to the discovery of hidden features of furniture pieces. A good case example would be discovery of secret compartments in a *sandook (cabinet)* while recording the measurements of the furniture for preparing the drawings.

Most of the craftspeople and communities who made these furniture pieces have stopped practising the craft forms owing to changing lifestyles. Technical drawings provide vital evidence of various techniques used by the craftspeople to shape vernacular furniture. They can support accurate conservation and restoration of damaged furniture. The drawings also capture the styles, forms and aesthetics of a region. This can act as an essential resource needed to keep the vernacular aesthetic in present day practices of furniture design.

Vernacular Furniture of North-West India project

Vernacular Furniture of North-West India is an international collaborative research project between Design Innovation and Craft Resource Centre (DICRC), CRDF, CEPT University, Ahmedabad, India and South Asian Decorative Arts and Craft Collection (SADACC) Trust, Norwich, UK. Initiated in December 2015, the project aimed at identifying, mapping, documenting and studying vernacular furniture that has traditionally been, and continues to be, an inherent part of the day-to-day life in an Indian household. North-west India covers the states of Gujarat, Rajasthan, Punjab and Haryana. The research was executed in three stages, Phase I: Gujarat, Phase II: Rajasthan and Phase III: Punjab & Haryana.

Vernacular furniture is used in the day-to-day life of people from a particular region or community. It is made by local craftspeople using indigenous materials. In a country like India, where the vernacular fabric changes every few hundred kilometres, a region's architecture, interior architecture and furniture reflect several social and cultural aspects of that particular region. Collectively these elements provide a unique identity to a community or a region as a whole. There exists a considerable amount of documentation and research on the traditional and vernacular architecture of India, there is not much to match it in terms of furniture. Academic material regarding the traditional and vernacular furniture of India is scarce, and there is none that sheds light on the origin or socio-cultural significance of the furniture pieces. This research project is an attempt to study the vernacular furniture of north-west India with respect to its form, function and making, as well as associated stories and myths that signify its relevance in a given context.

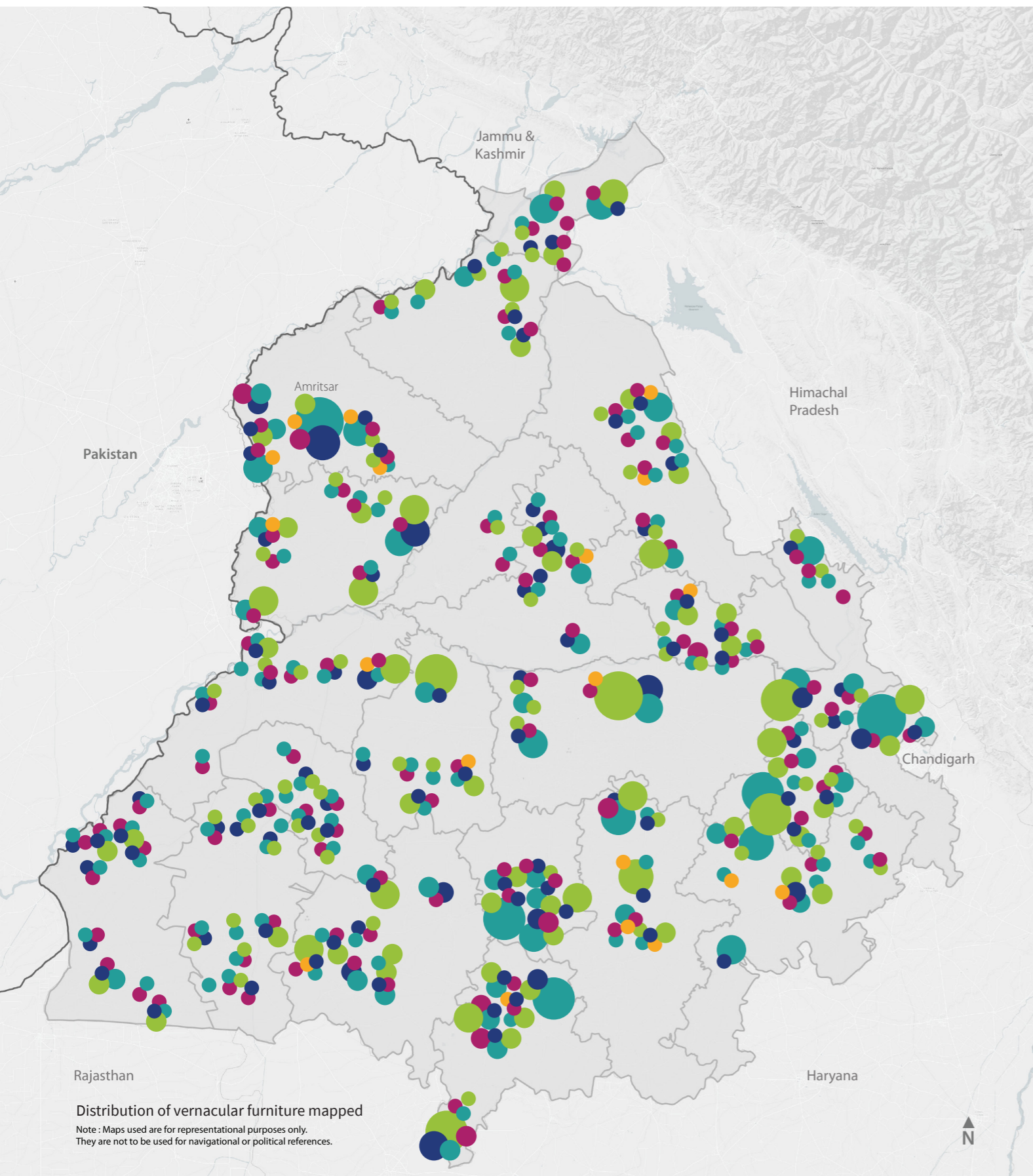

Categories



Aasan is derived from the Sanskrit word *asana*. It signifies body-posture as well as a seat. The term *aasan* is ambiguous in nature and encompasses anything from a straw mat to a king's throne. All types of seating furniture have been classified under this category.

Manch, among various other implications, signifies a bed. Vernacular beds are essentially charpoy. A variety of charpoy forms and other vernacular furniture pieces, like cradles, are used for sleeping and are included in this category.

Manjush is derived from the Sanskrit term '*manjusha*', meaning a storage space. In different parts of north-west India, *manjush* is also known as *majus* or *majju*, because of the change in vernacular dialect from region to region. A range of storage furniture including in-built options like wall niches and cabinets, are included in this category.

Various surfaces are used to place objects upon, to write on or are used in ceremonial contexts. *Sapaat* is a term used to denote any such horizontal surface.

An object is known as *vastu*, in most north-western languages. The term is not to be confused with *vaastu*, which signifies a house, or the land to build a house on. Everyday objects such as caskets, hooks, lamps, shrines, hand mills and so on that have been an integral component of domestic lifestyles are featured under this category.

Legend

NUMBER OF ELEMENTS



Categories



Typology of Furniture: Punjab

Aasan seating

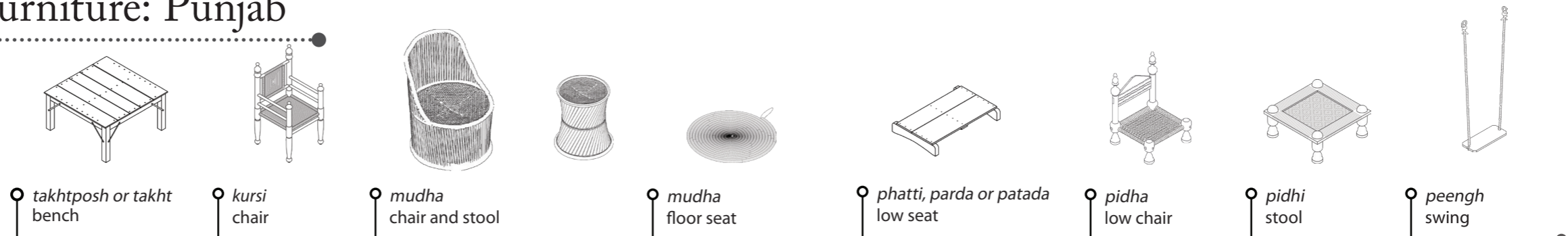

takhtposh or takht bench kursi chair mudha chair and stool mudha floor seat phatti, parda or patada low seat pidha low chair pidhi stool peengh swing

Manch sleeping

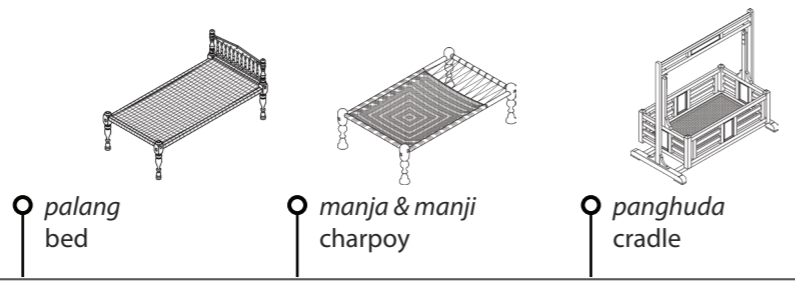

palang bed manja & manji charpoy panghuda cradle

Manjush storage

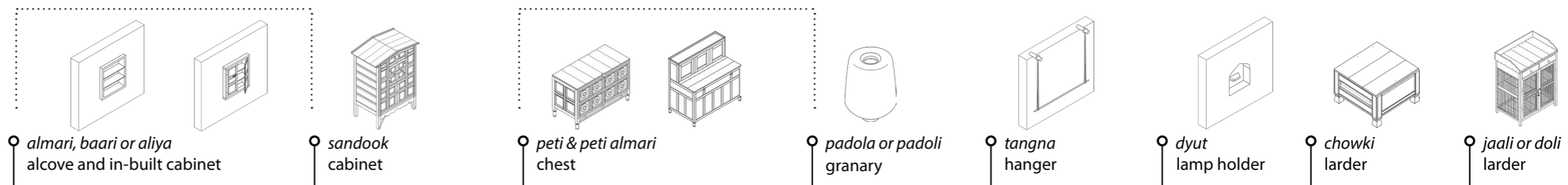

almari, baari or aliya alcove and in-built cabinet sandook cabinet peti & peti almari chest padola or padoli granary tangna hanger dyut lamp holder chowki larder jaali or doli larder

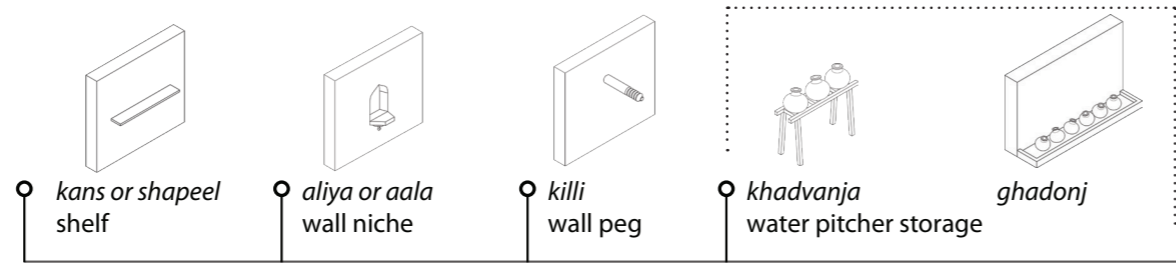

kans or shapeel shelf aliya or aala wall niche killi wall peg khadvanja water pitcher storage ghadonj

Sapaat surface

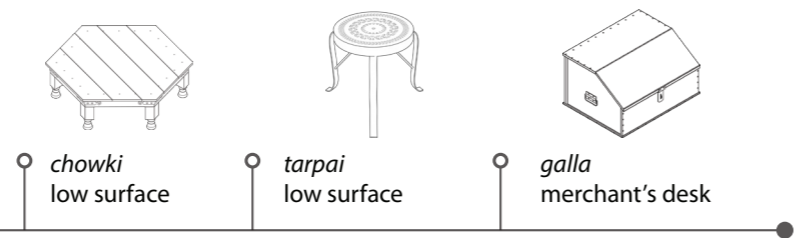

chowki low surface tarpai low surface galla merchant's desk

Vastu objects

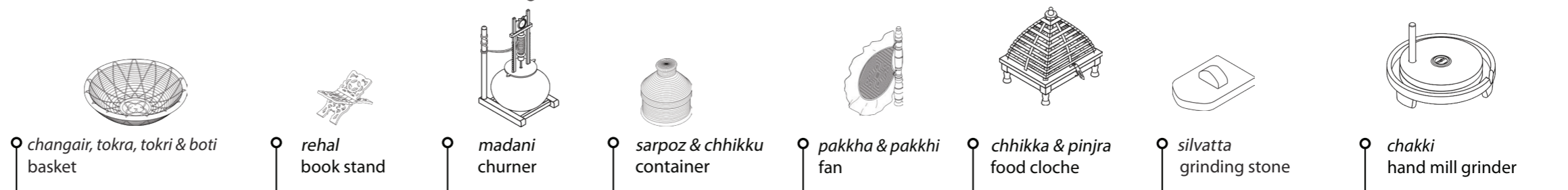

changair, tokra, tokri & boti basket rehal book stand madani churner sarpoz & chhikku container pakkha & pakkhi fan chhikka & pinjra food cloche silvatta grinding stone chakki hand mill grinder

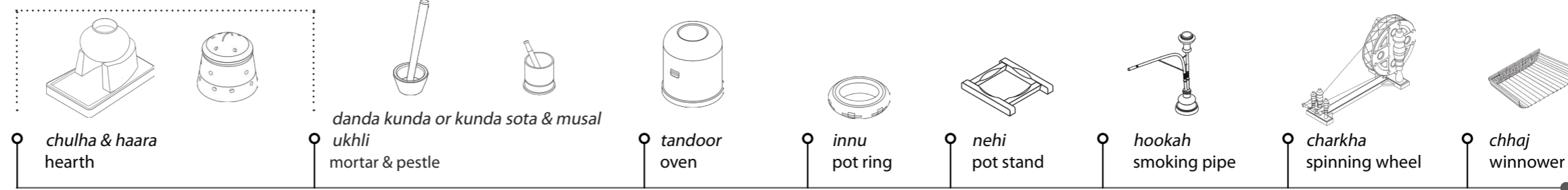

chulha & haara hearth danda kunda or kunda sota & musal ukhli mortar & pestle tandoor oven innu pot ring nehi pot stand hookah smoking pipe charkha spinning wheel chhaj winnower



aasan
seat

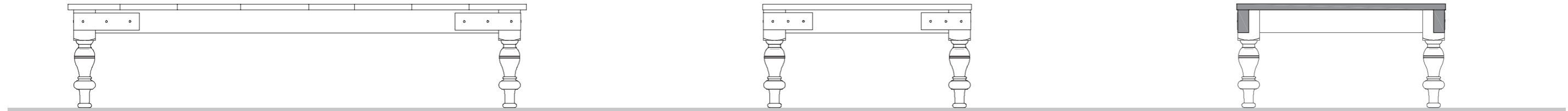

Front elevation

Side elevation

Section 1

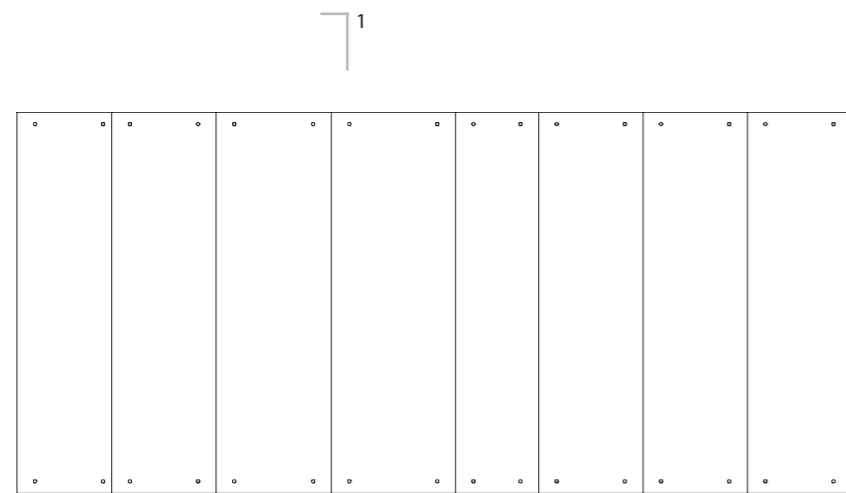

Plan (Top View)

Vernacular Furniture of Punjab



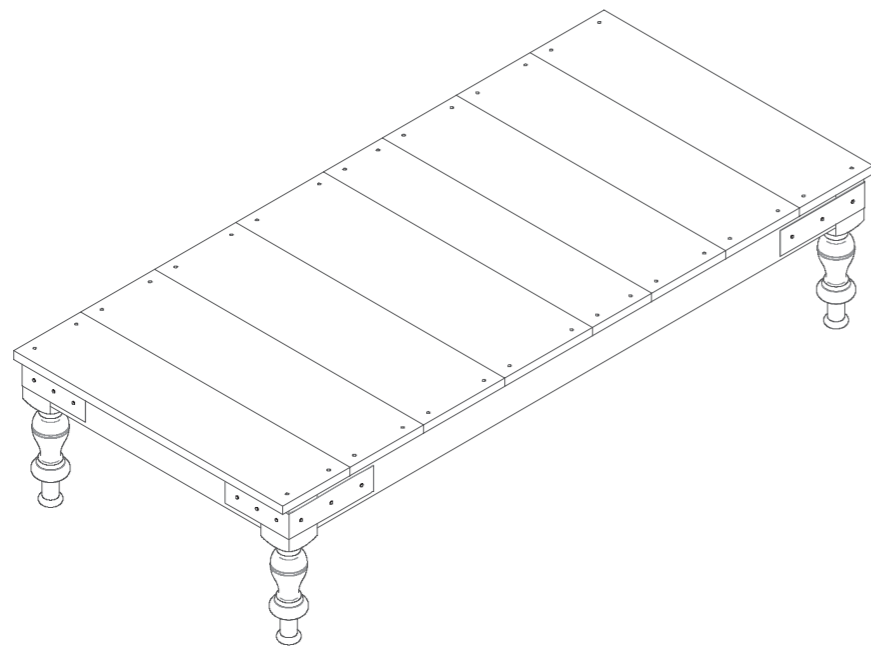

Isometric View

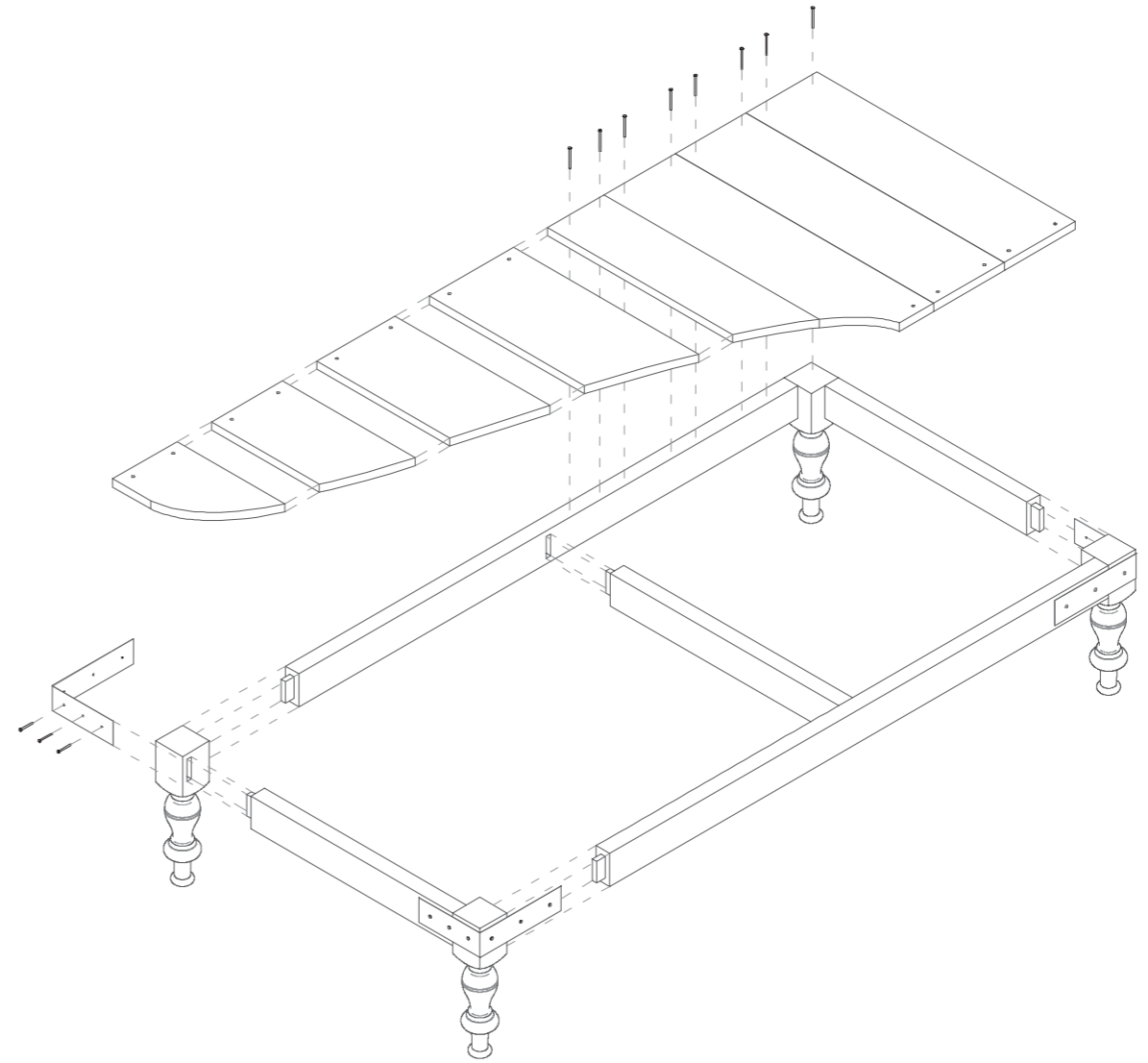

Exploded Isometric View



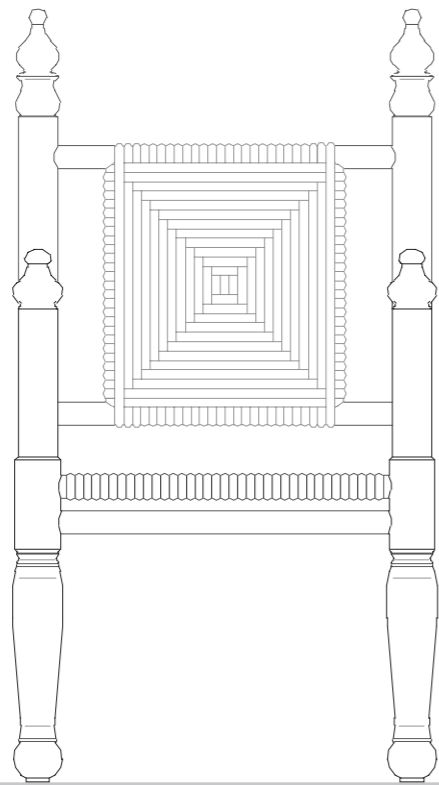

Front elevation

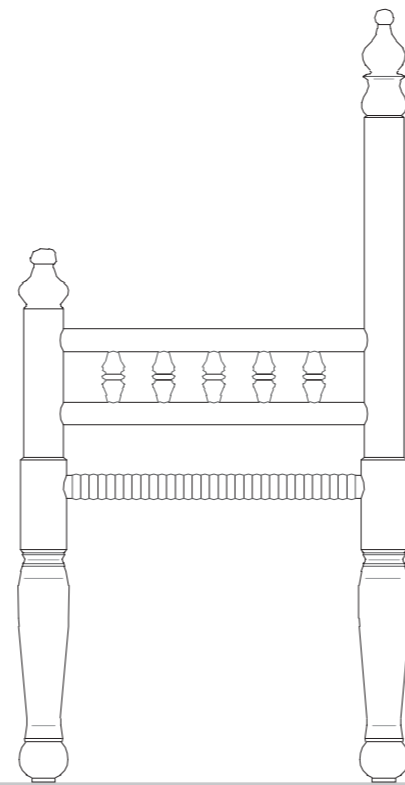

Side elevation

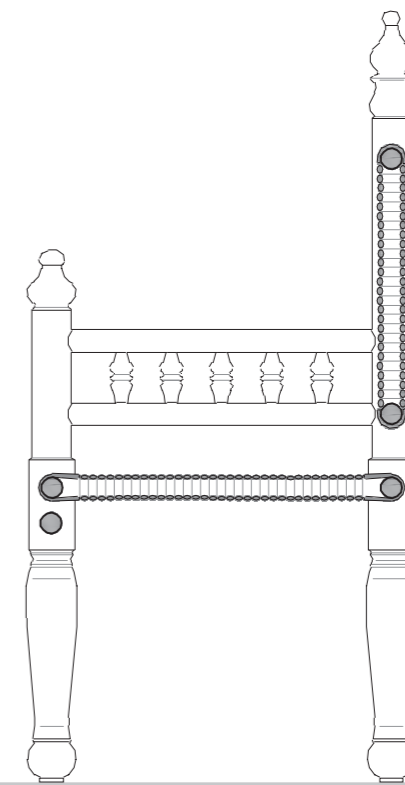

Section 1

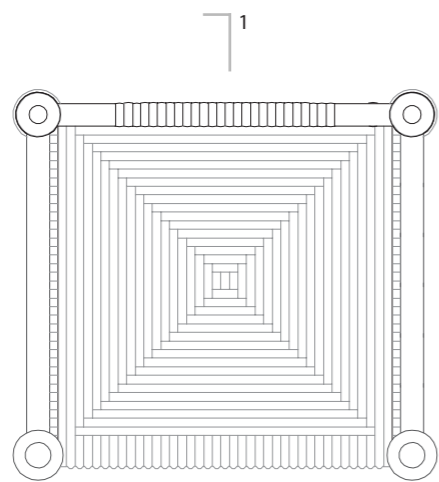

Plan (Top View)



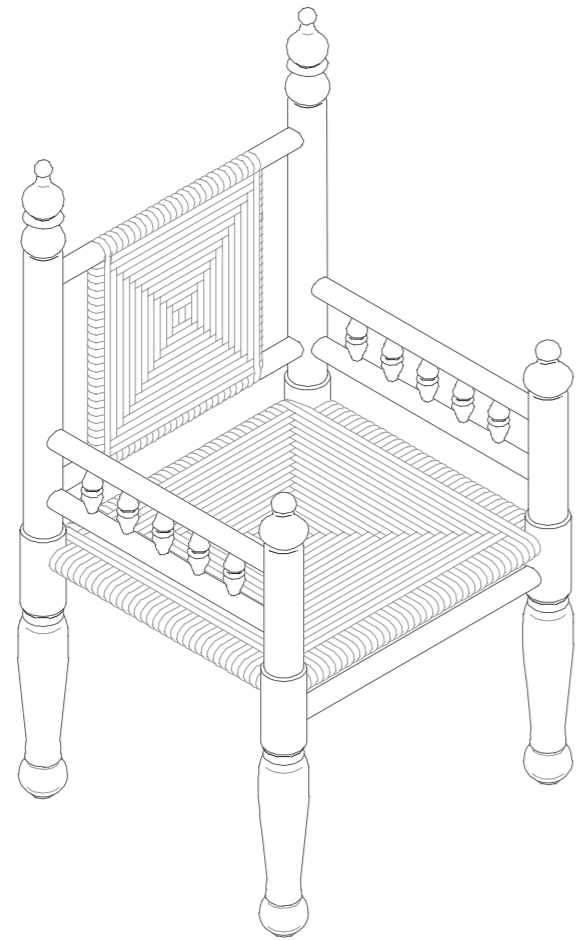

Isometric View

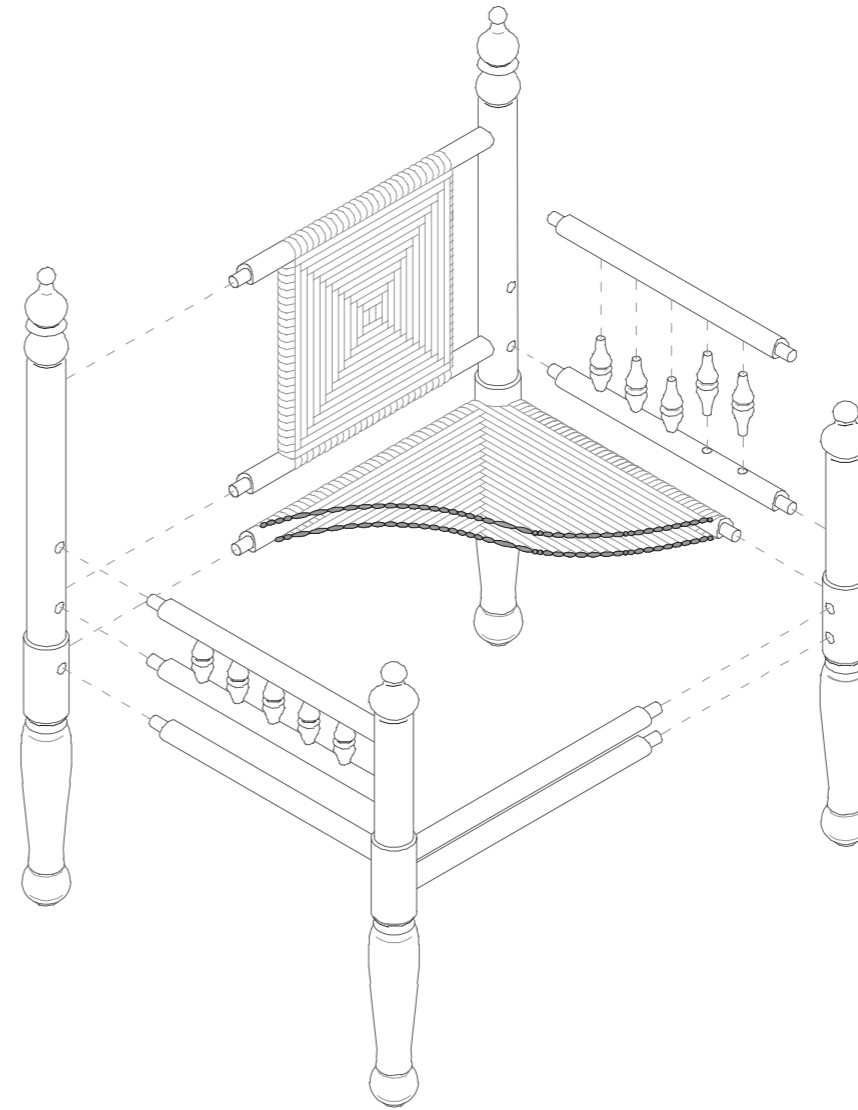

Exploded Isometric View



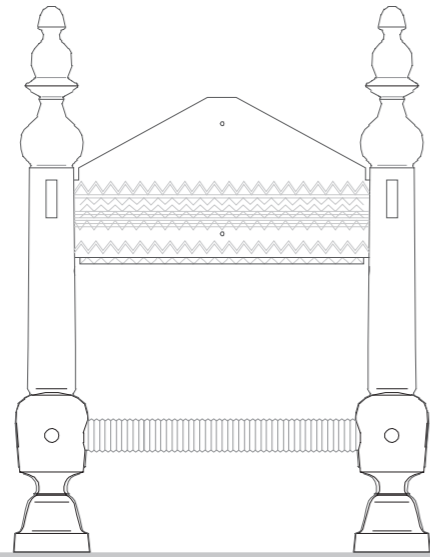

Front elevation

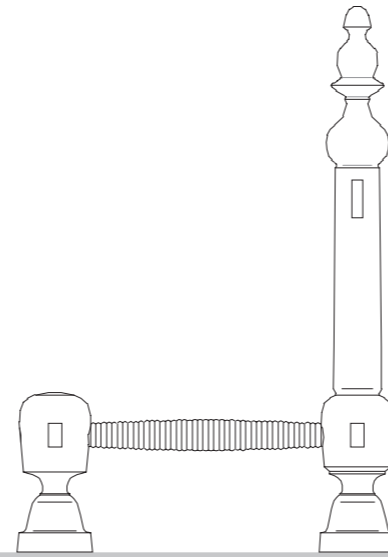

Side elevation

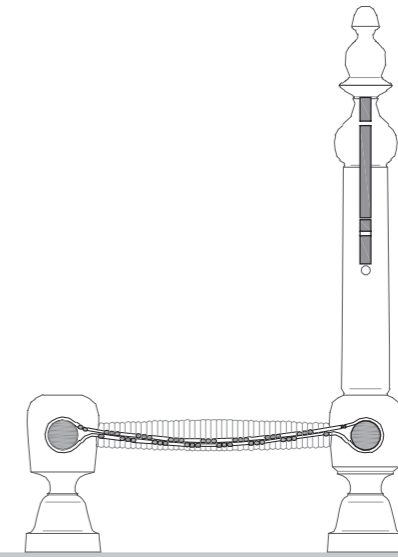

Section 1

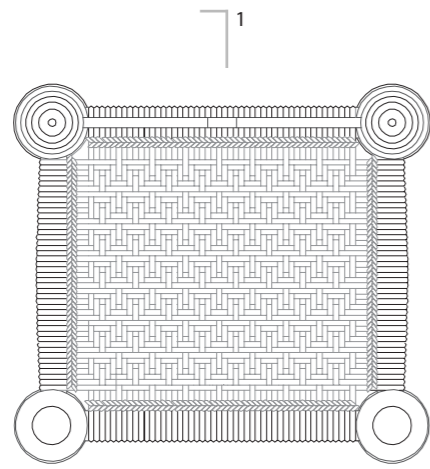

Plan (Top View)



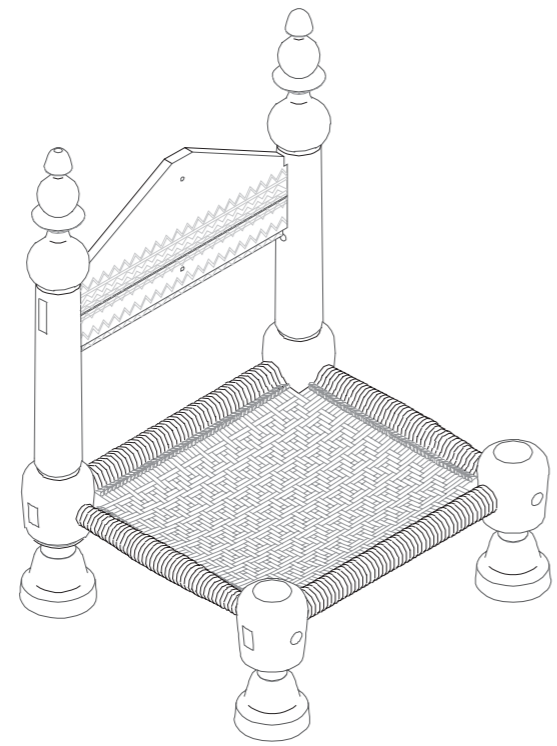

Isometric View

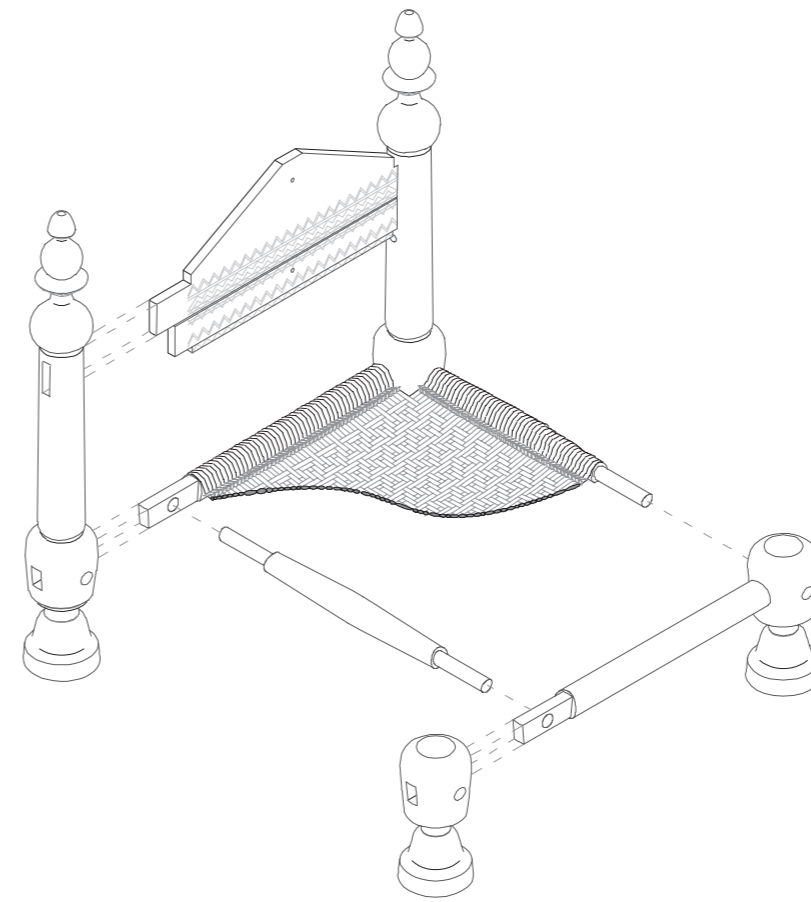

Exploded Isometric View





Side elevation



Section 1

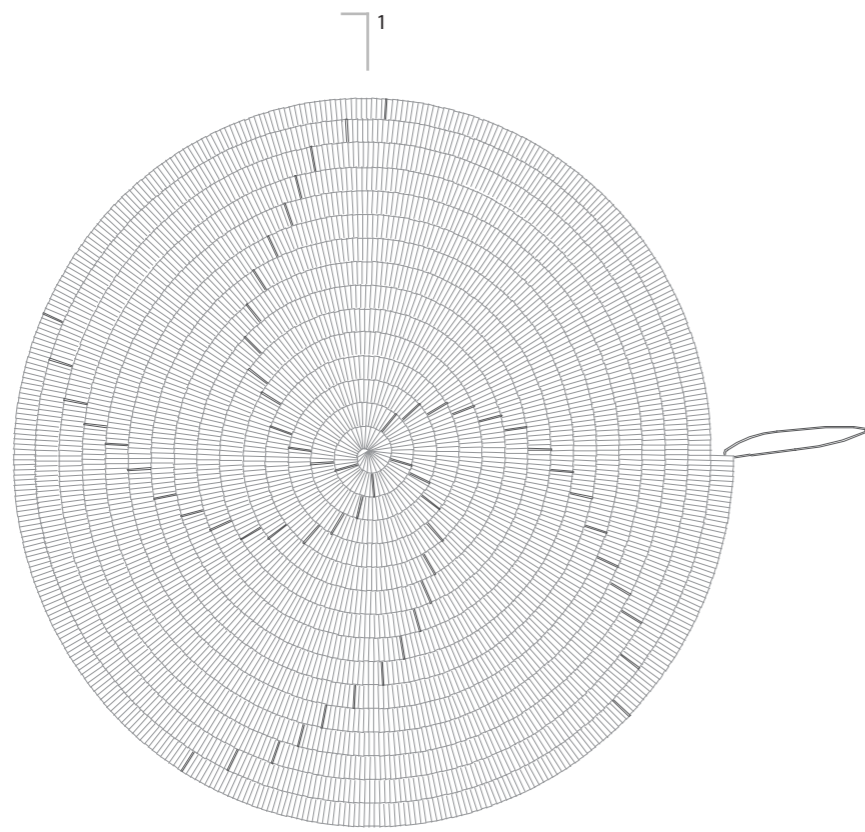

Plan (Top View)

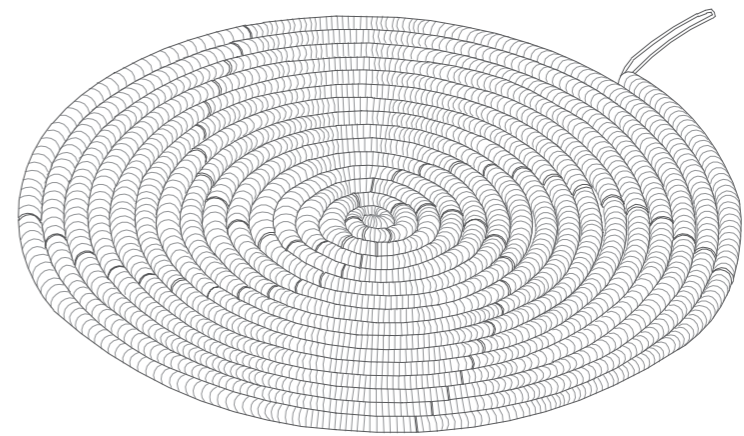

Isometric view



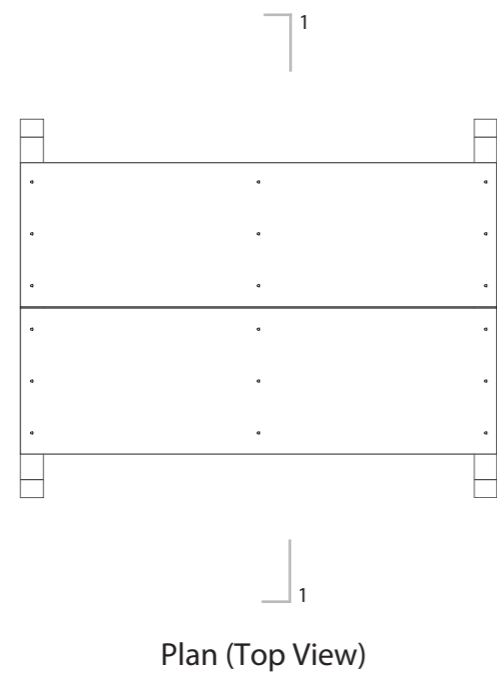
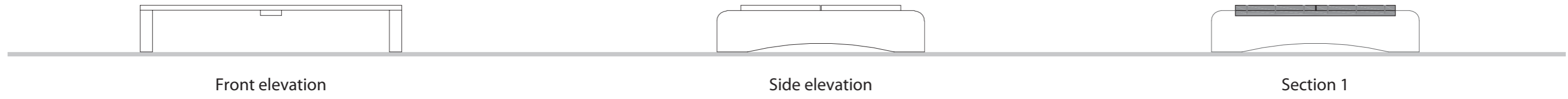

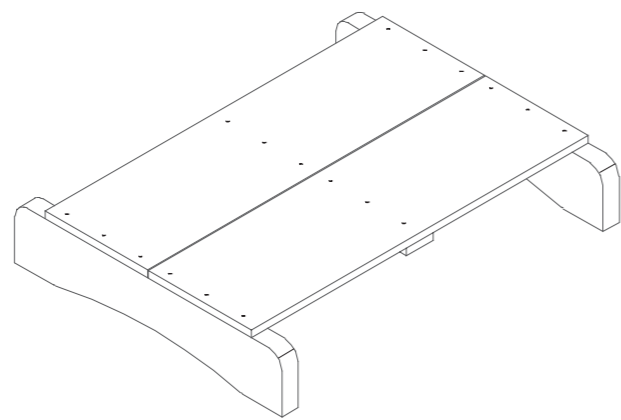

Plan (Top View)

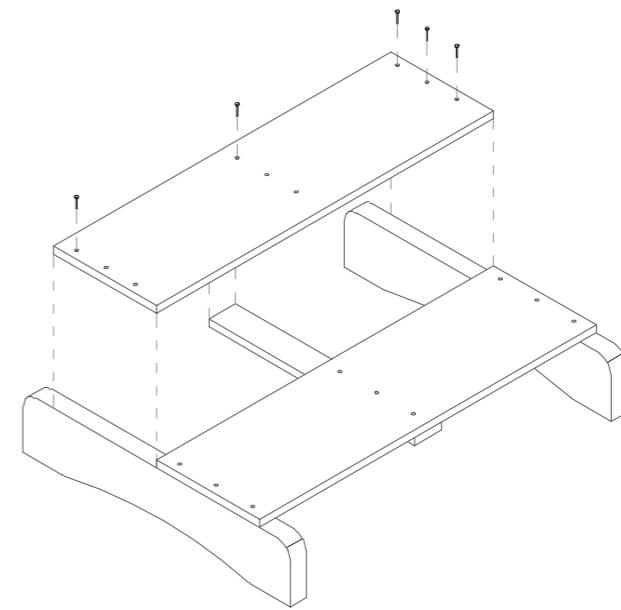

Plan (Top View)



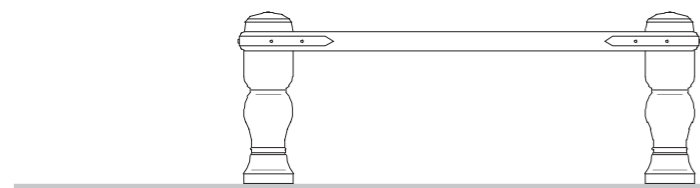

Front elevation

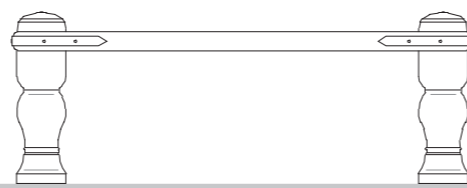

Side elevation

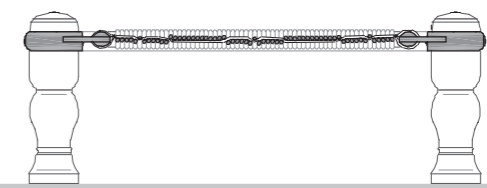

Section 1

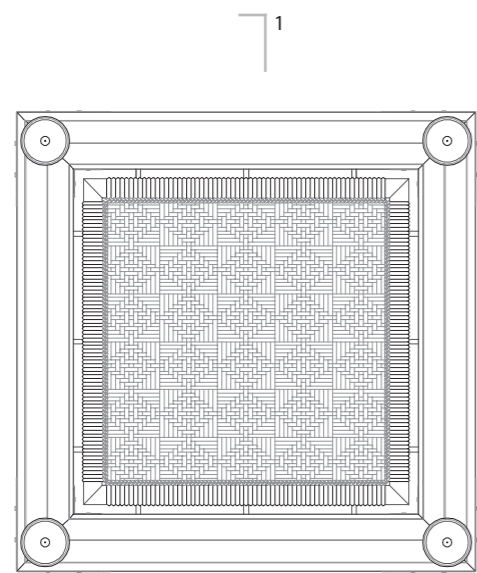

Plan (Top View)



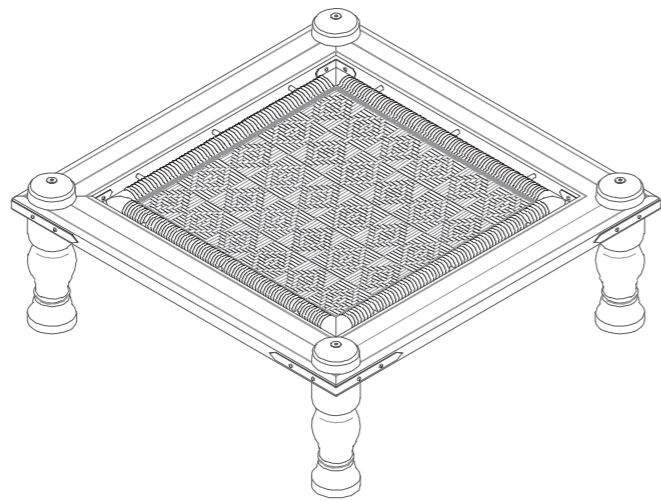

Isometric view

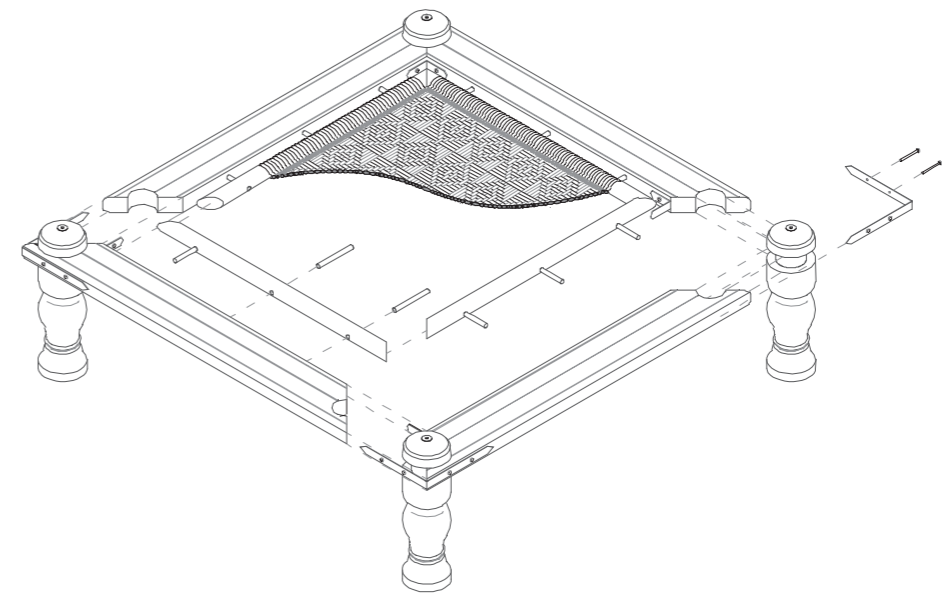

Exploded Isometric view



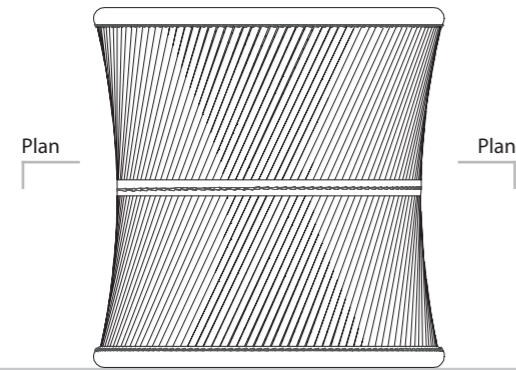

Front elevation

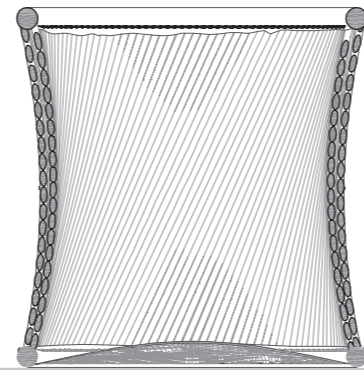

Section 1

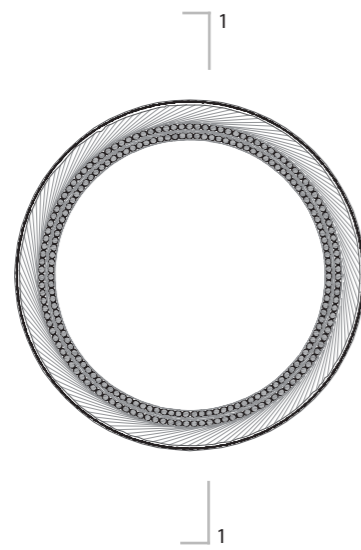

Plan

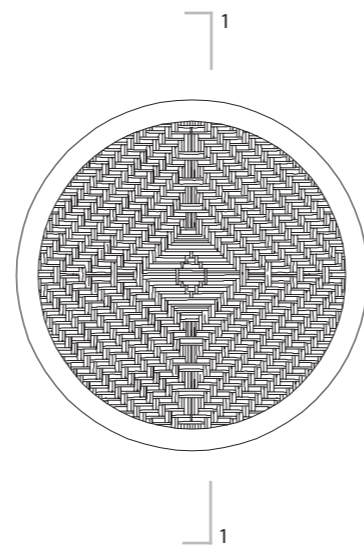

Plan (Top View)



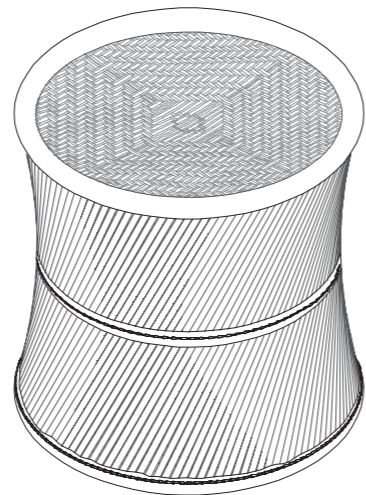

Isometric view

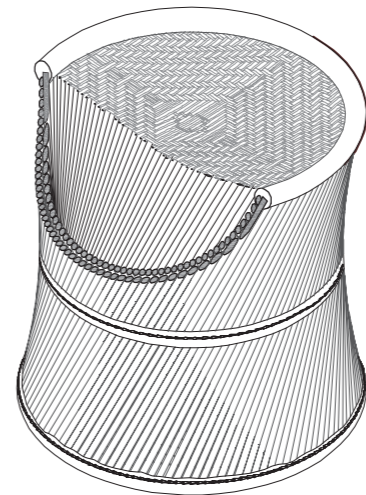

Isometric view (cut)



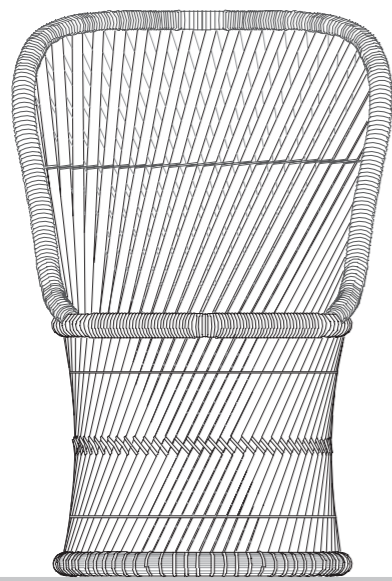

Front elevation

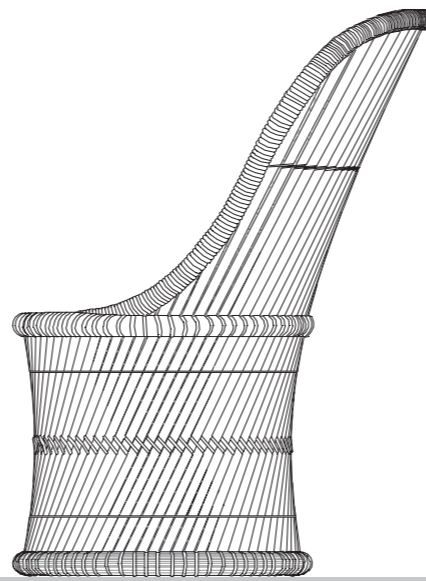

Side elevation

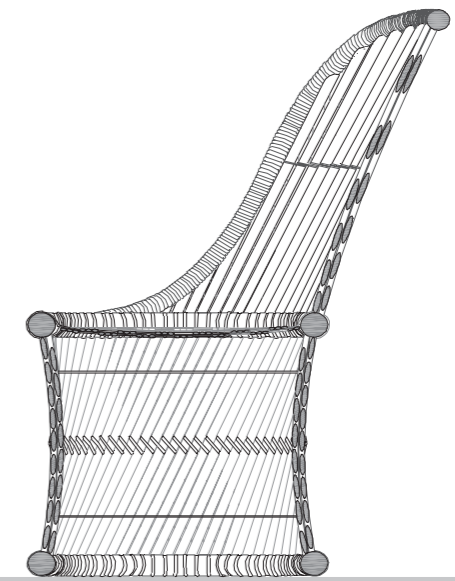

Section 1

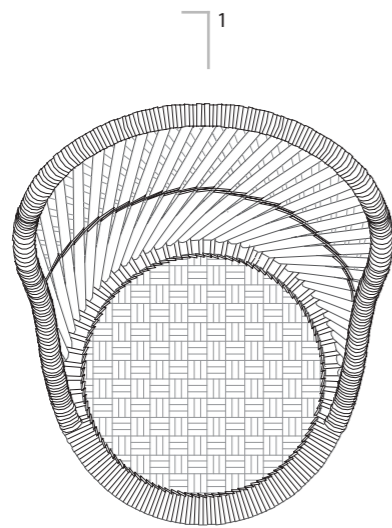

Plan (Top View)



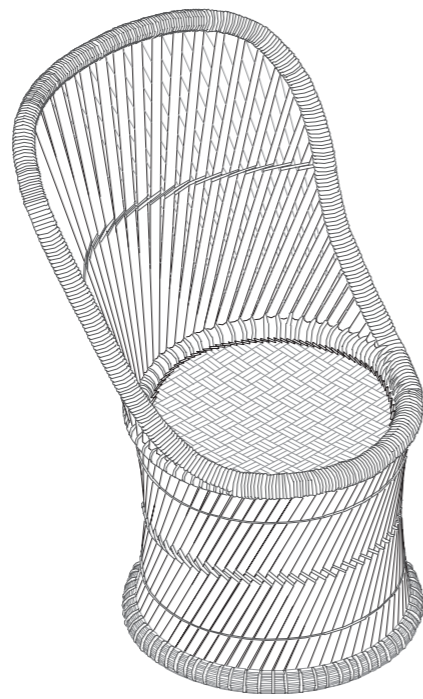

Isometric view

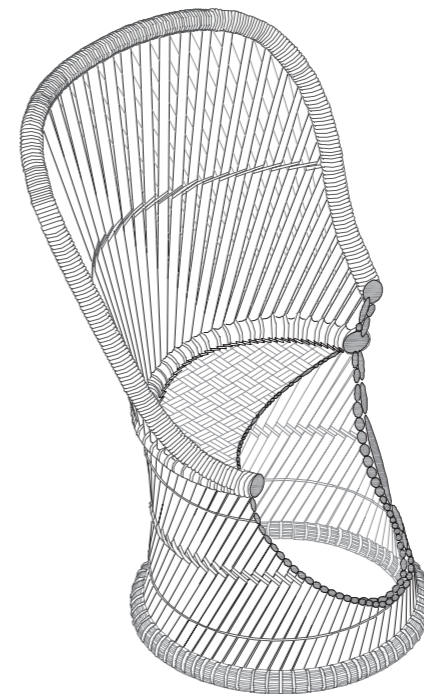

Exploded Isometric view



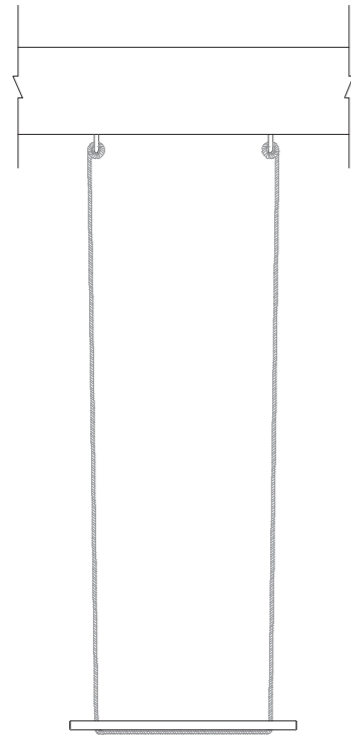

Front elevation

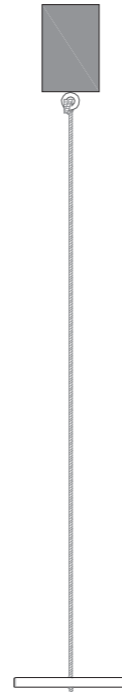

Side elevation

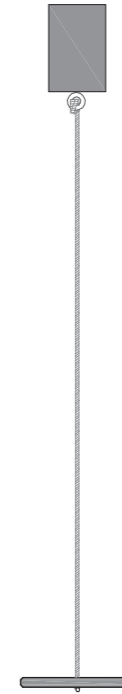

Section 1

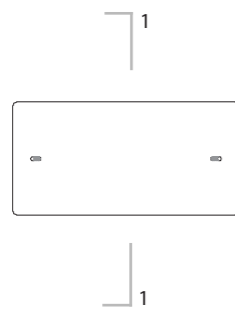

Plan (Top View)



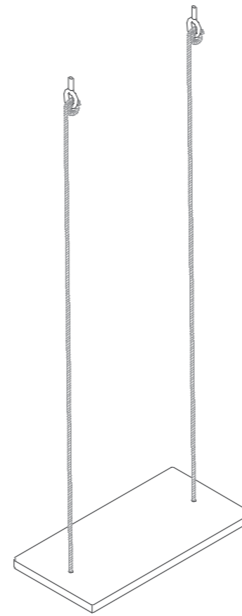

Isometric view



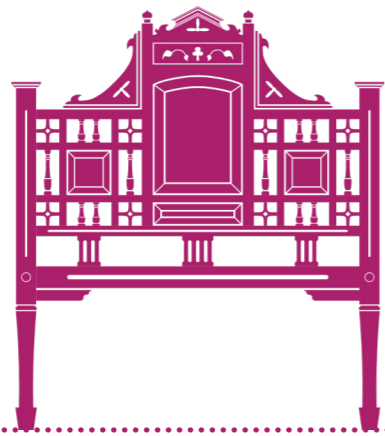

manch
bed

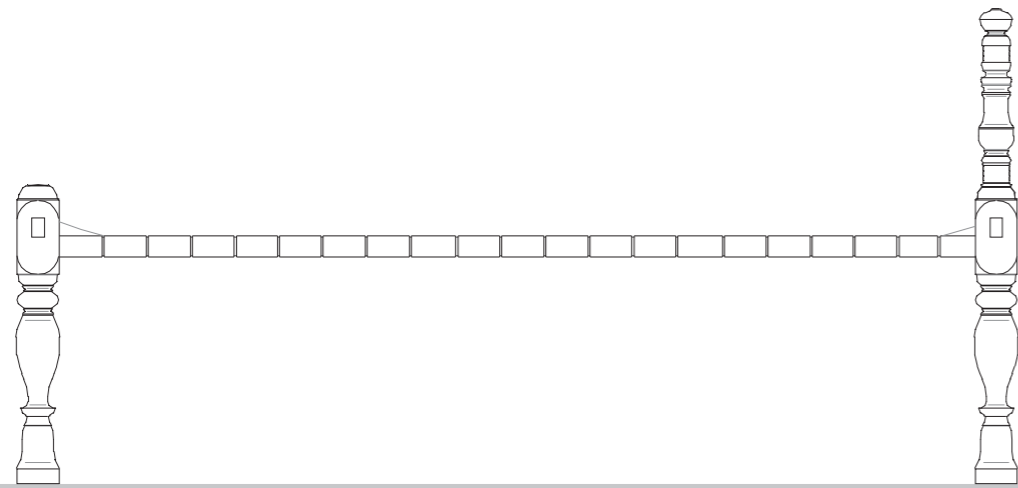

Front elevation

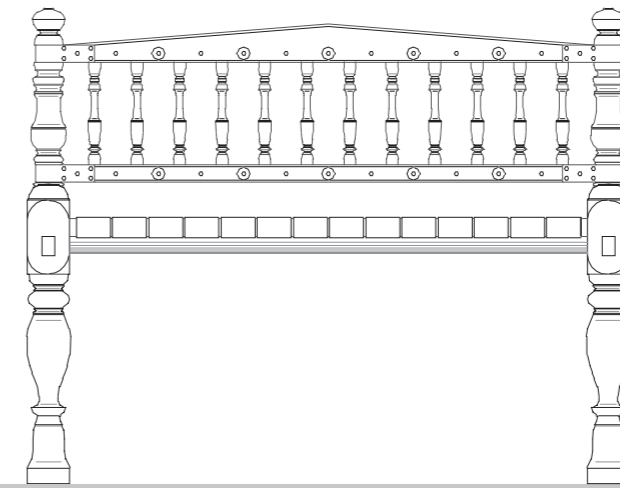

Side elevation

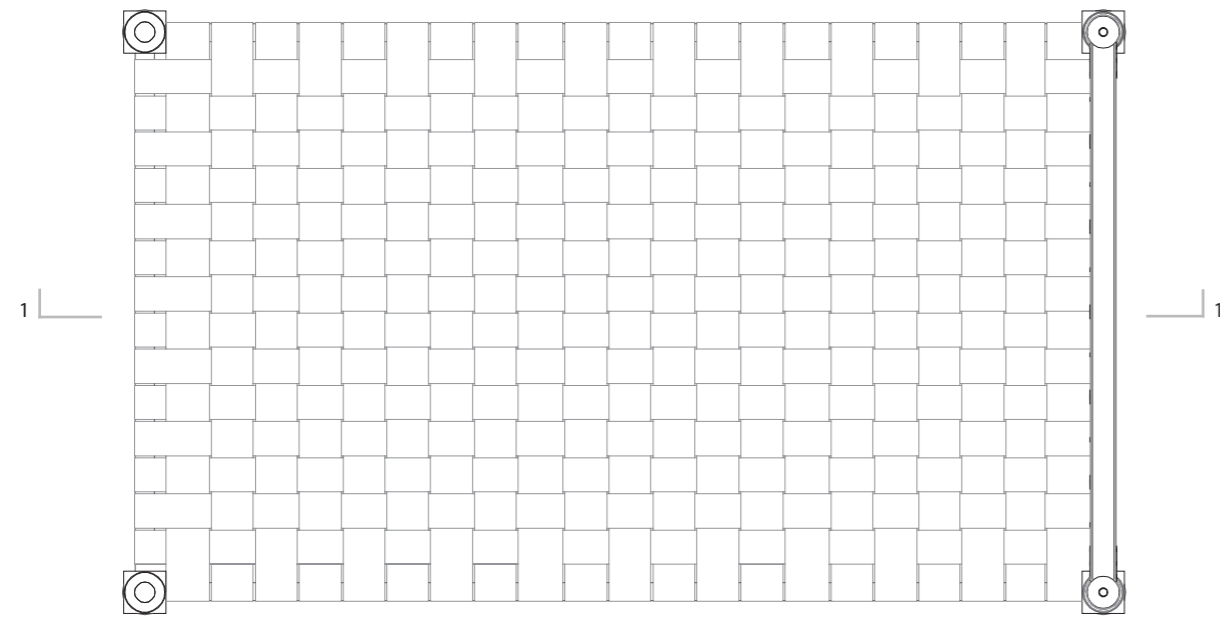

Plan (Top View)

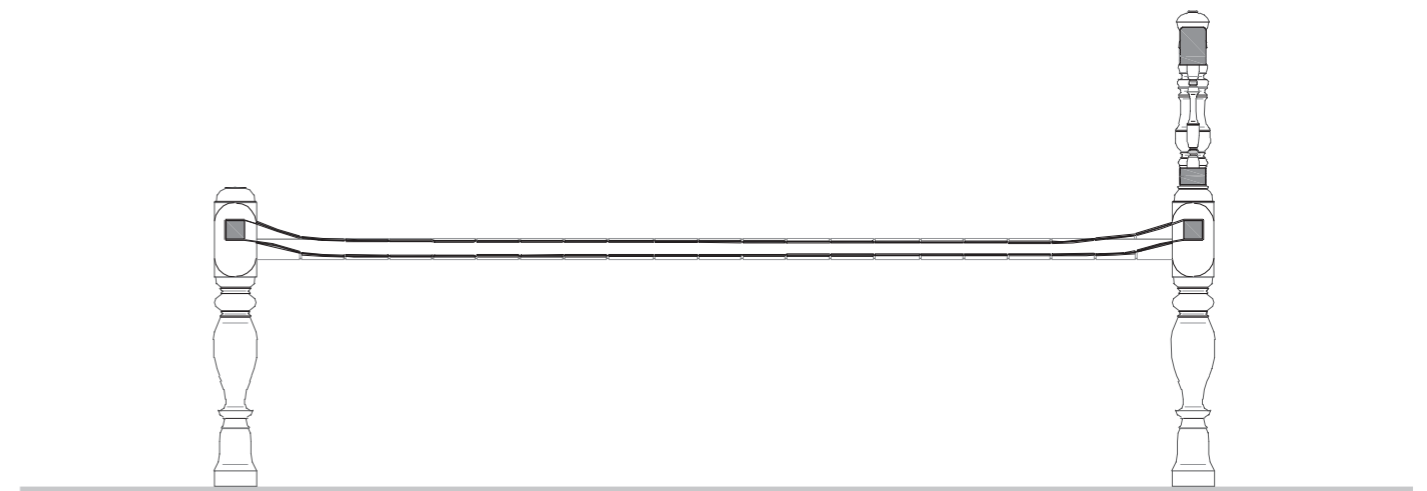

Section 1

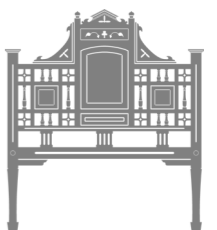

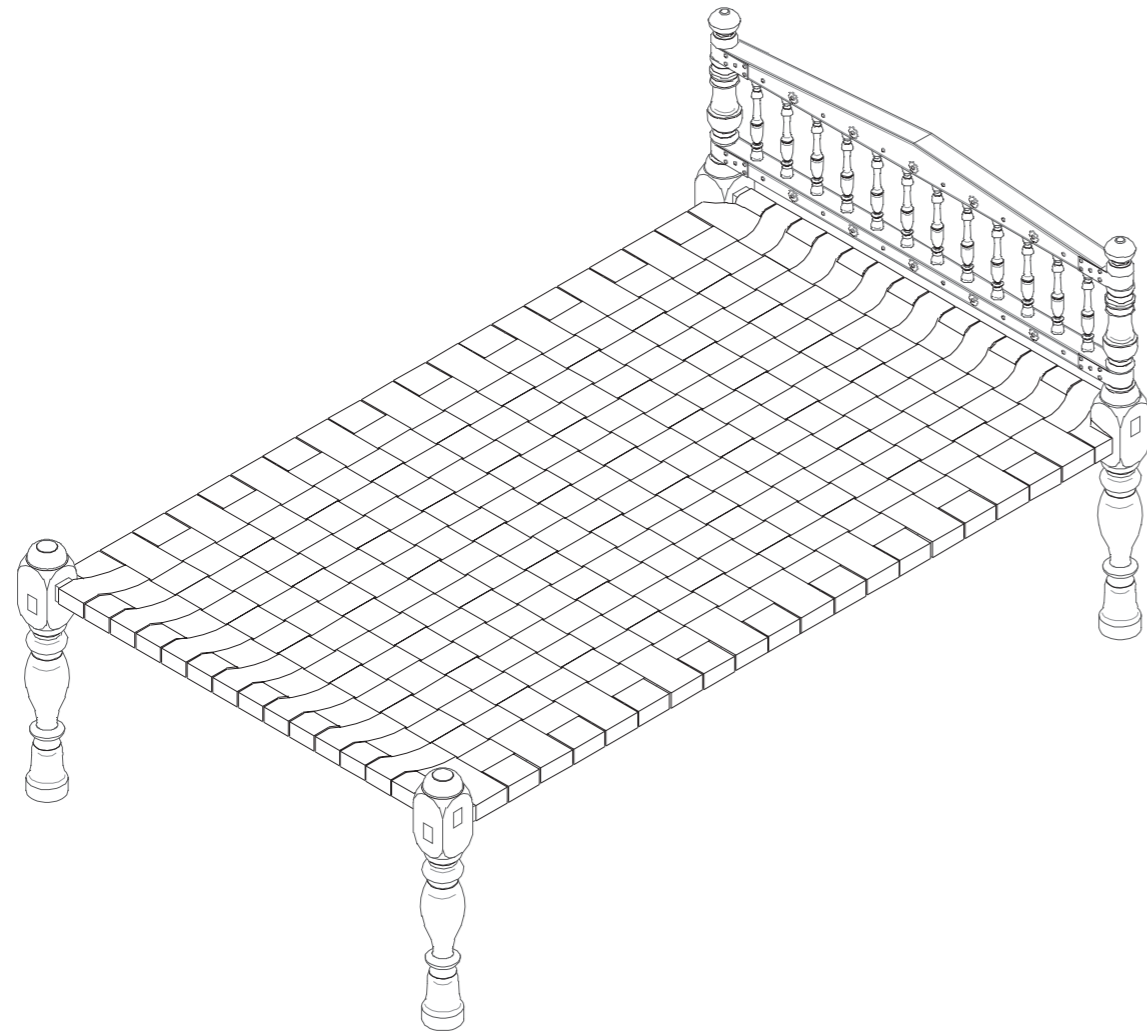

Isometric View

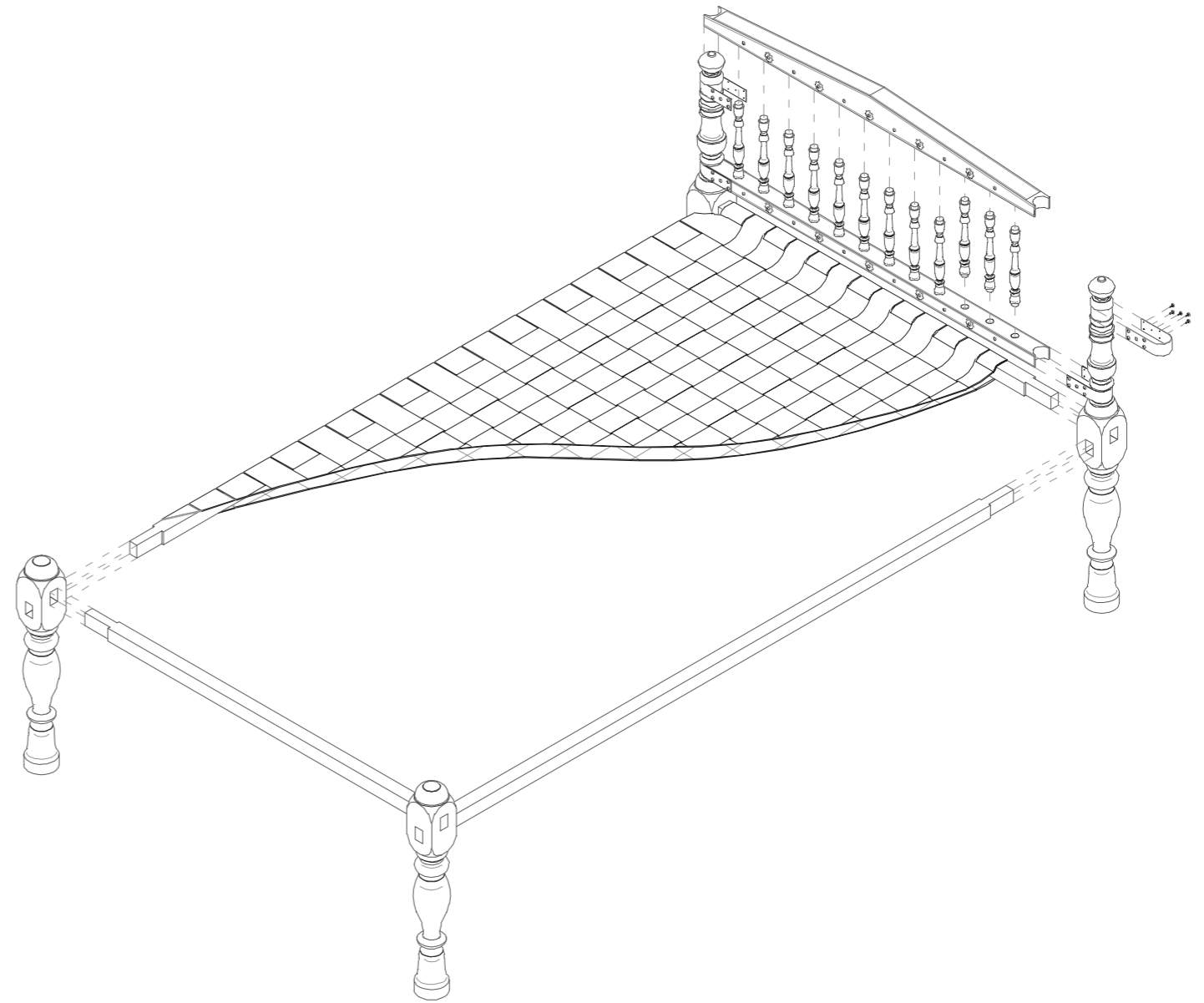

Exploded Isometric View

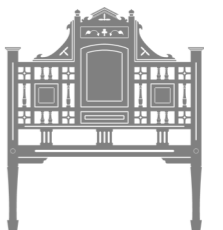

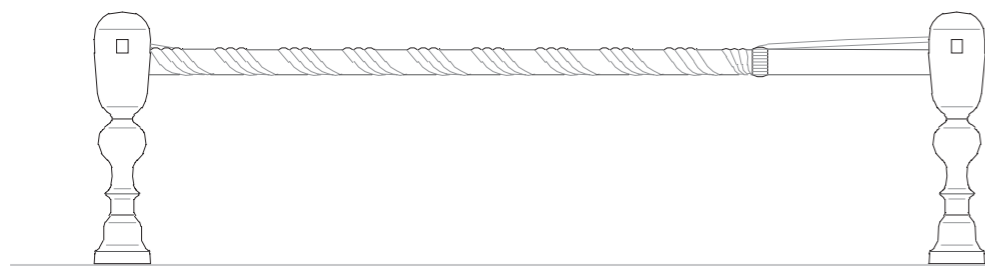

Front elevation

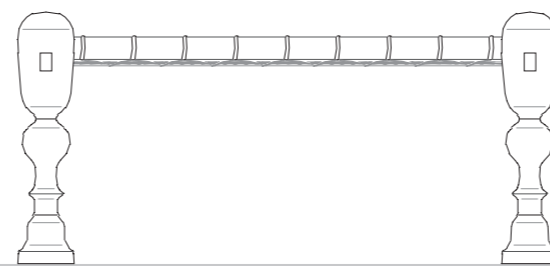

Side elevation

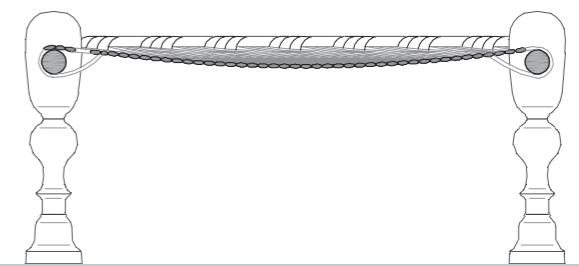

Section 1

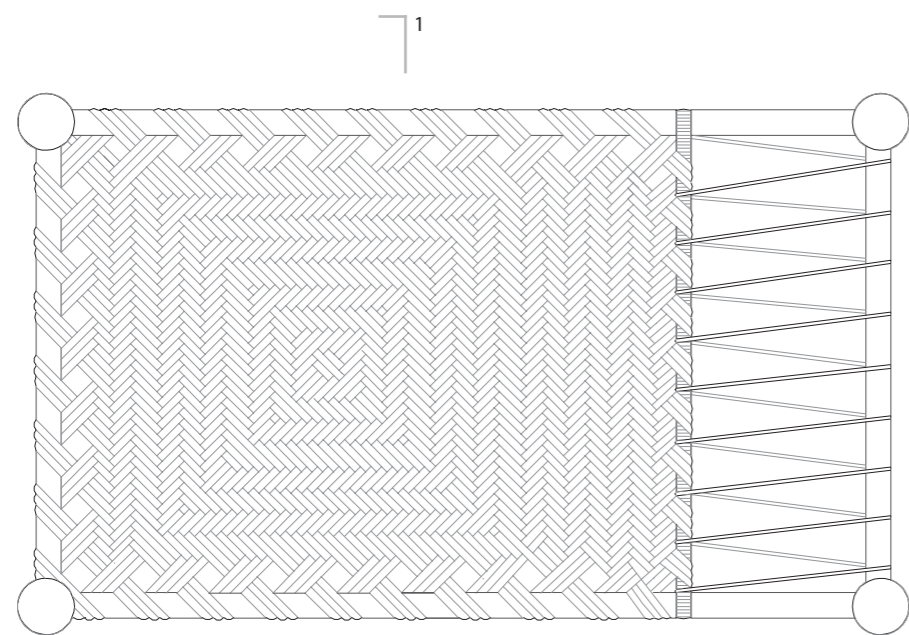

Plan (Top View)

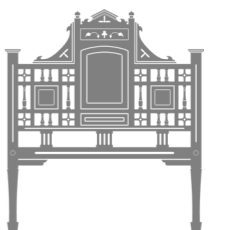

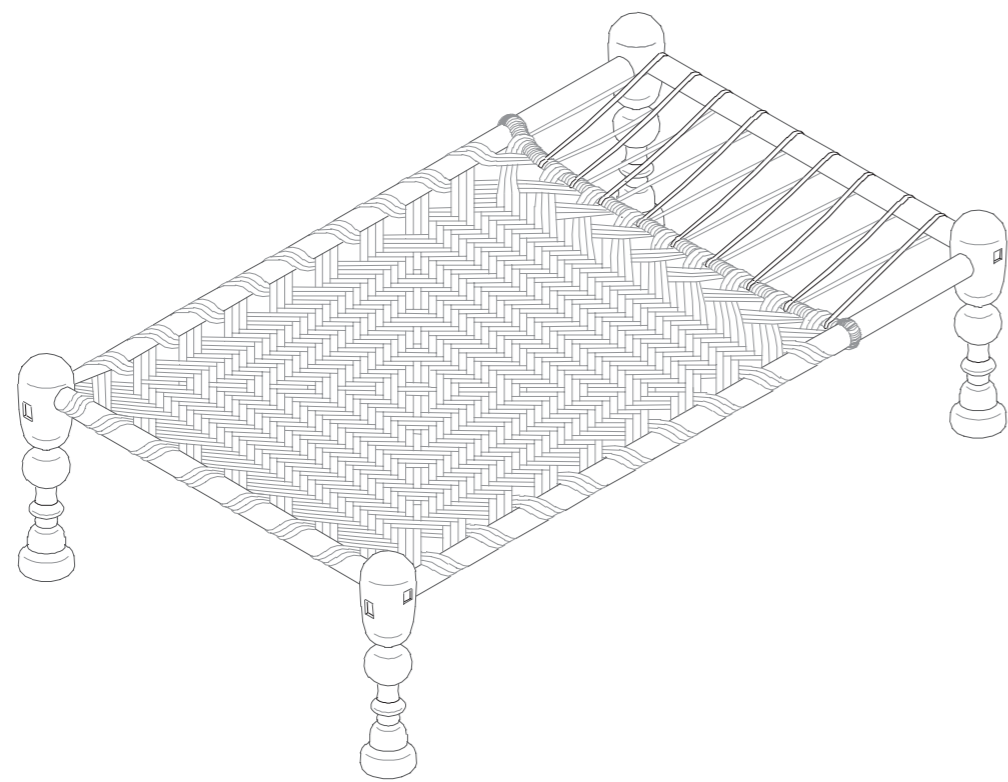

Isometric View

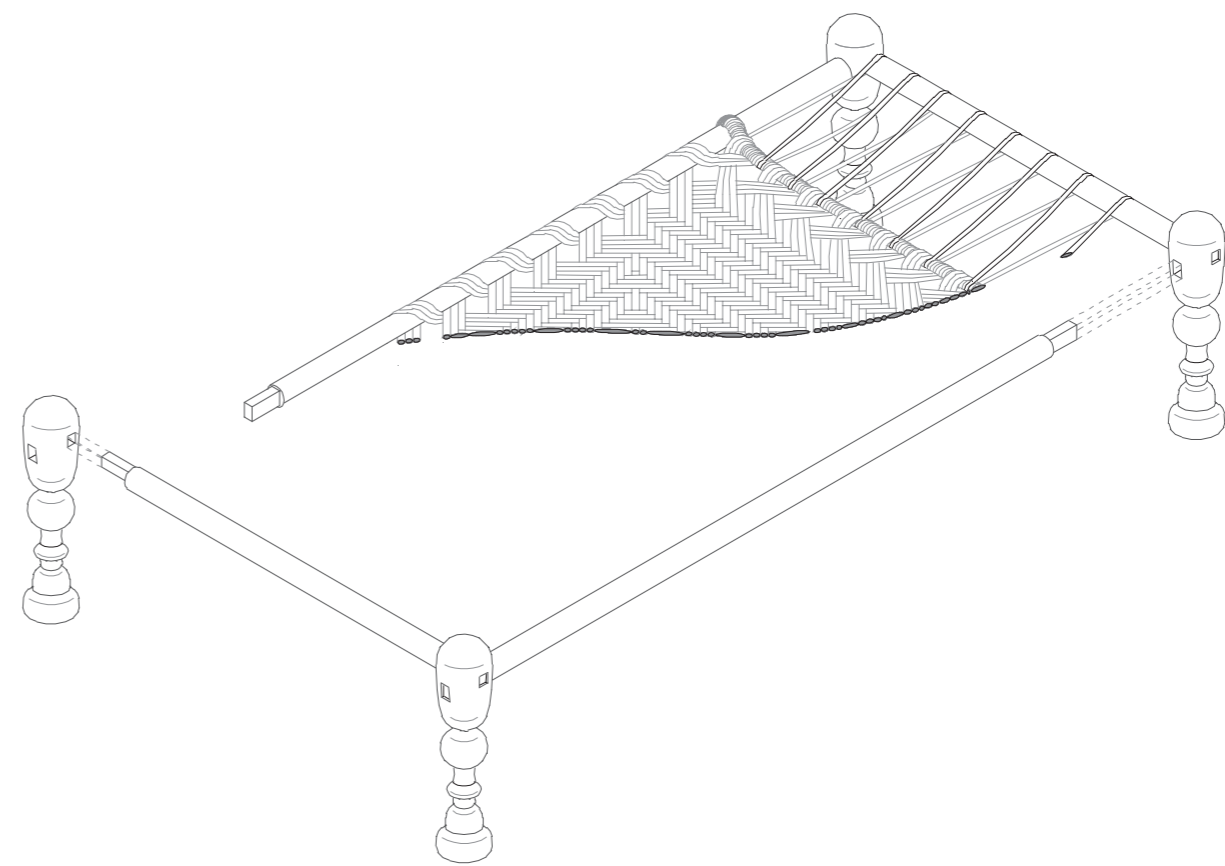

Exploded Isometric View

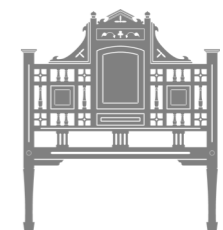

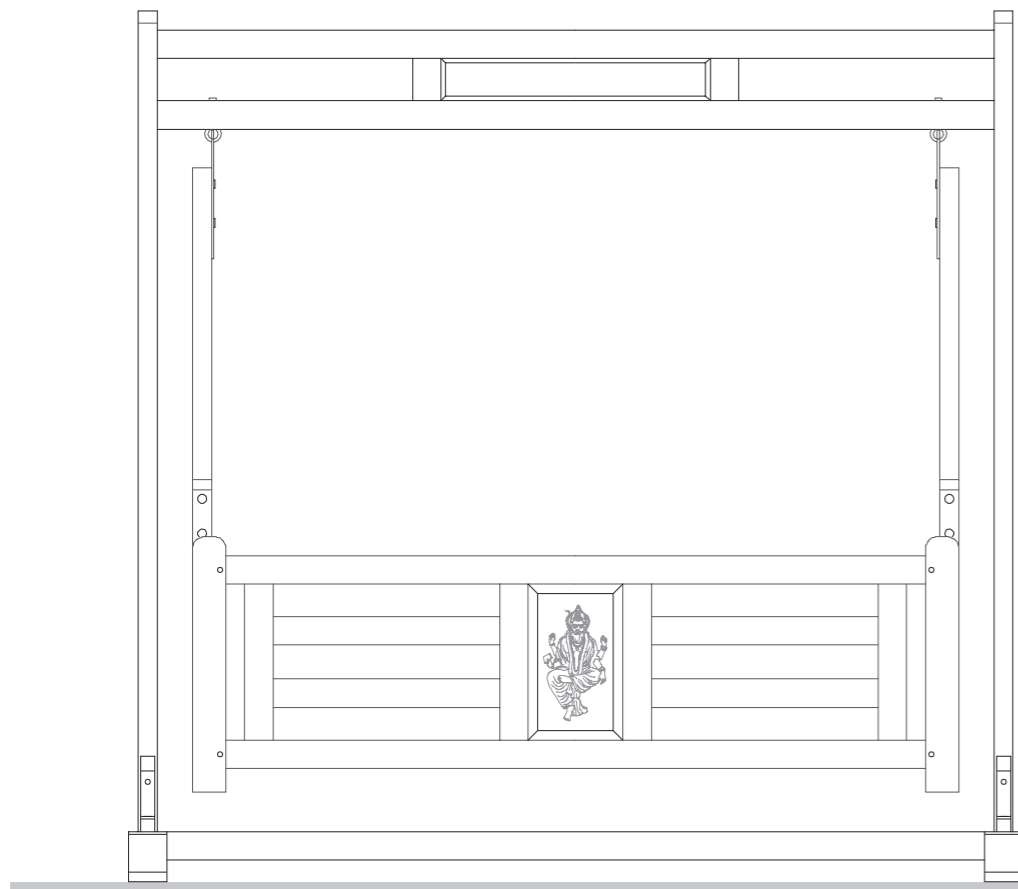

Front elevation

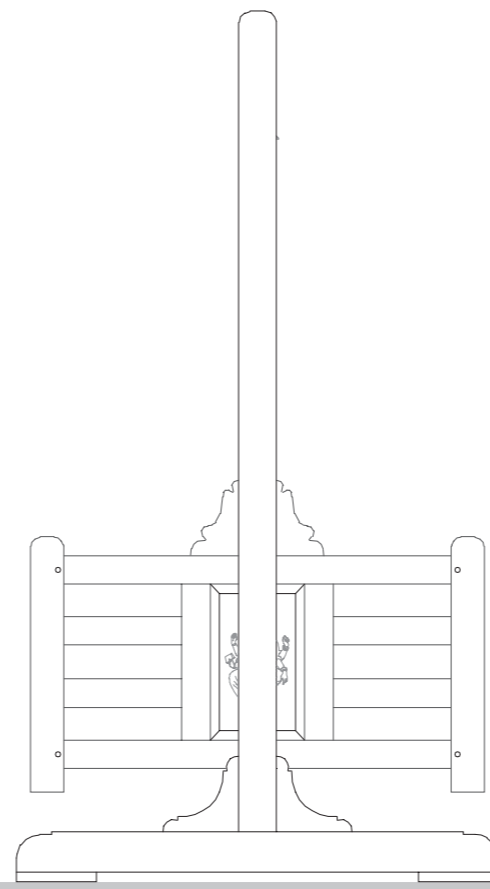

Side elevation

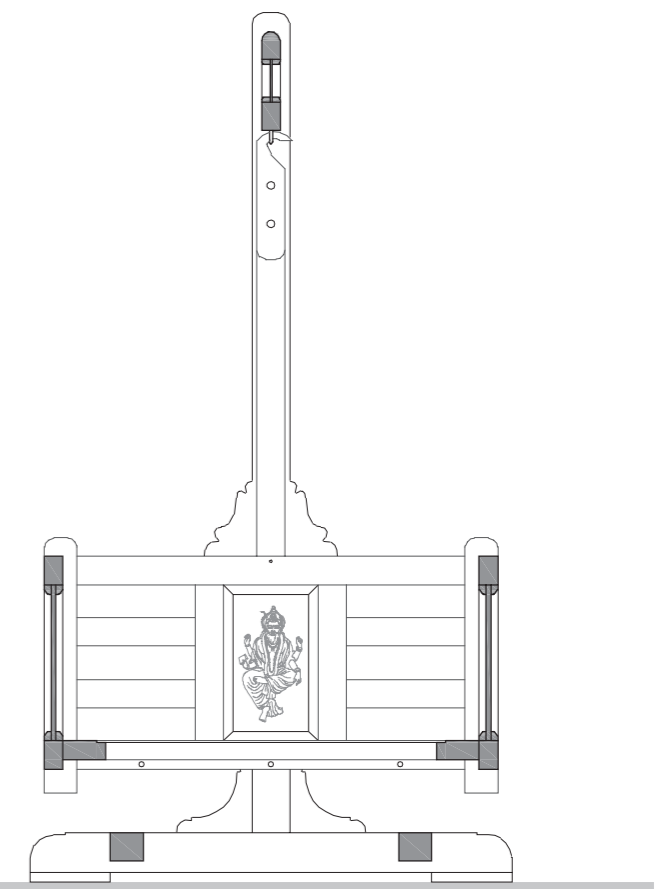

Section 1

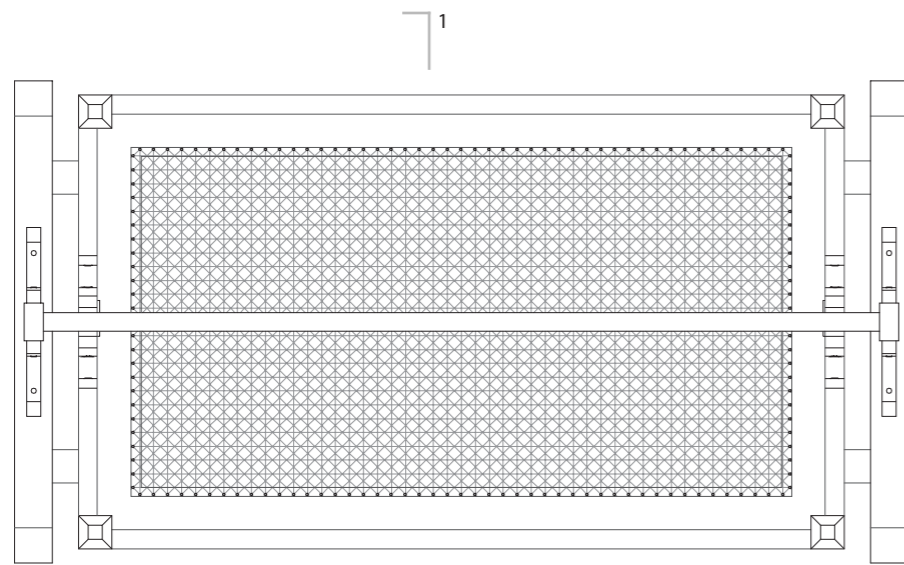

Plan (Top View)

Vernacular Furniture of Punjab

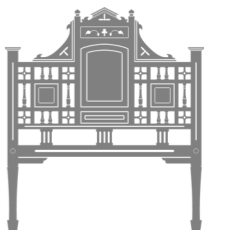

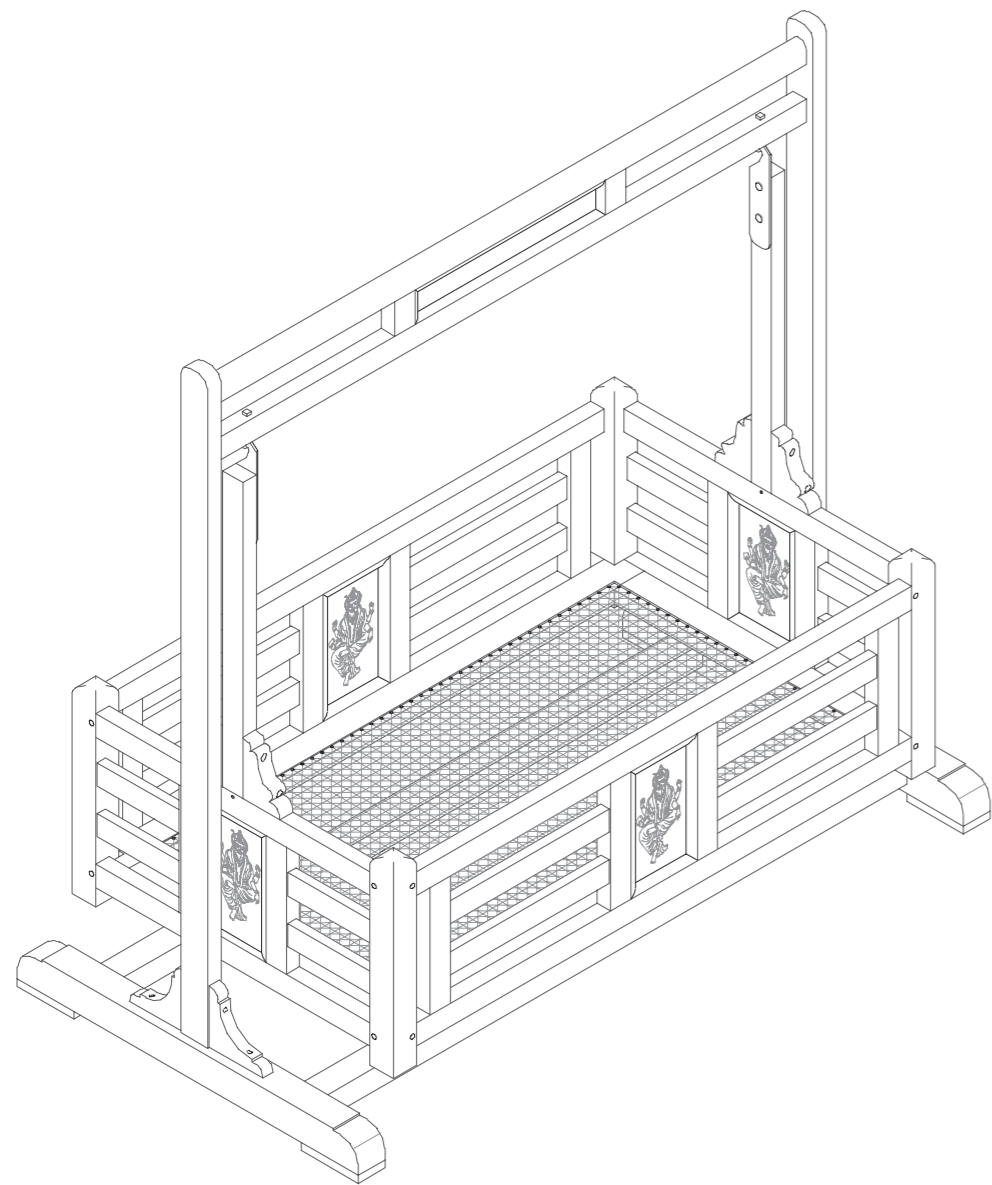

Isometric view

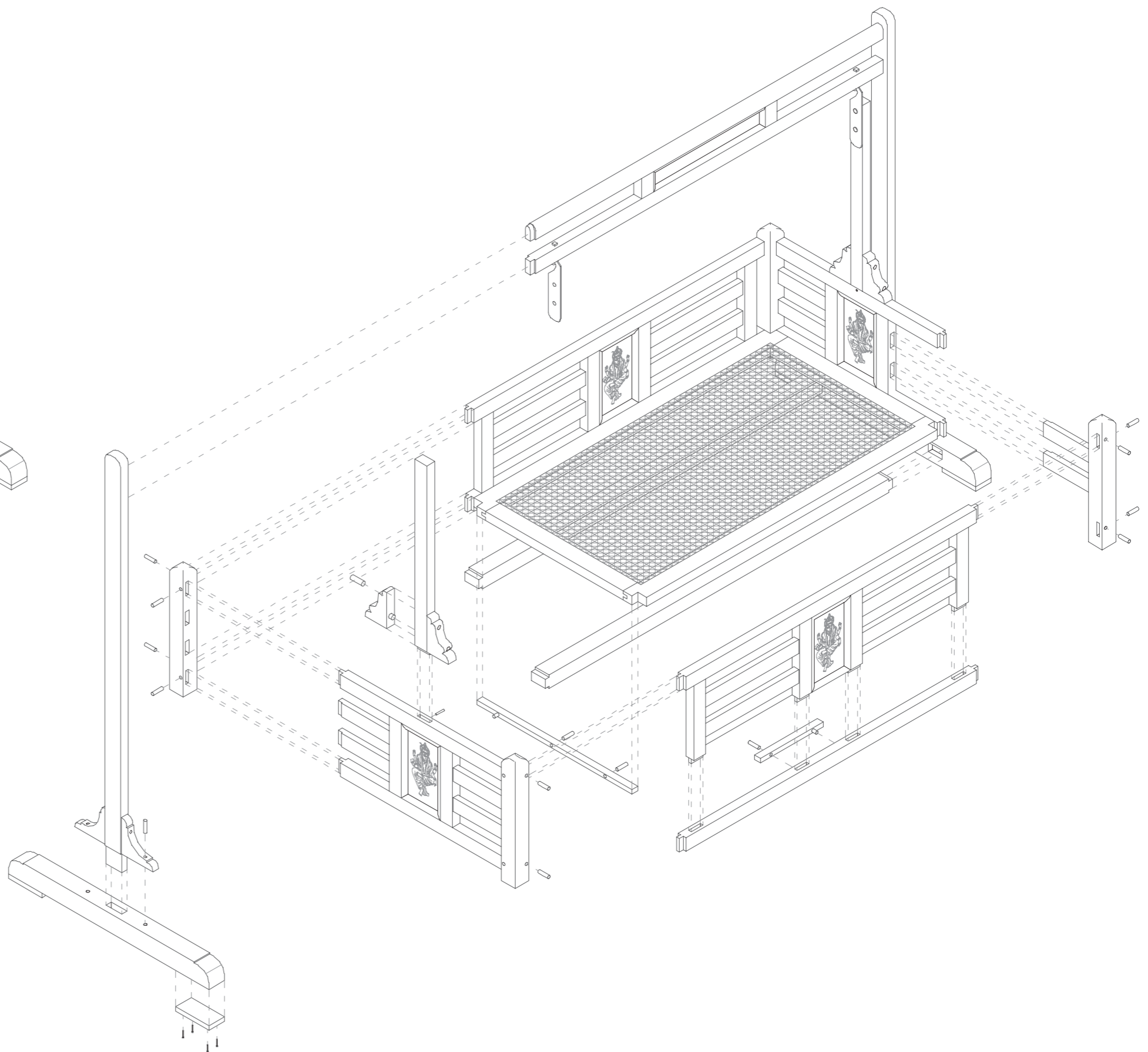

Exploded Isometric view

Vernacular Furniture of Punjab

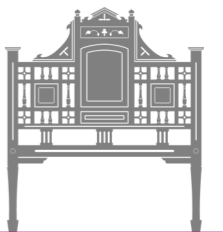

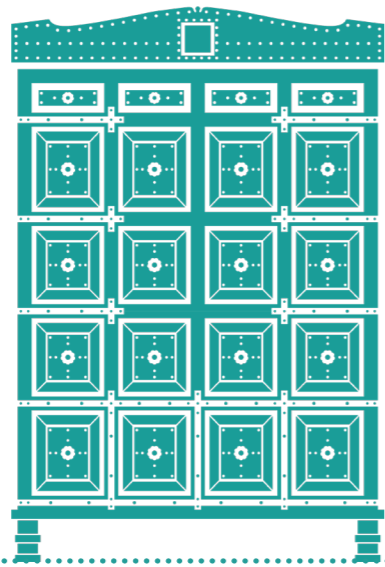

manjush
storage

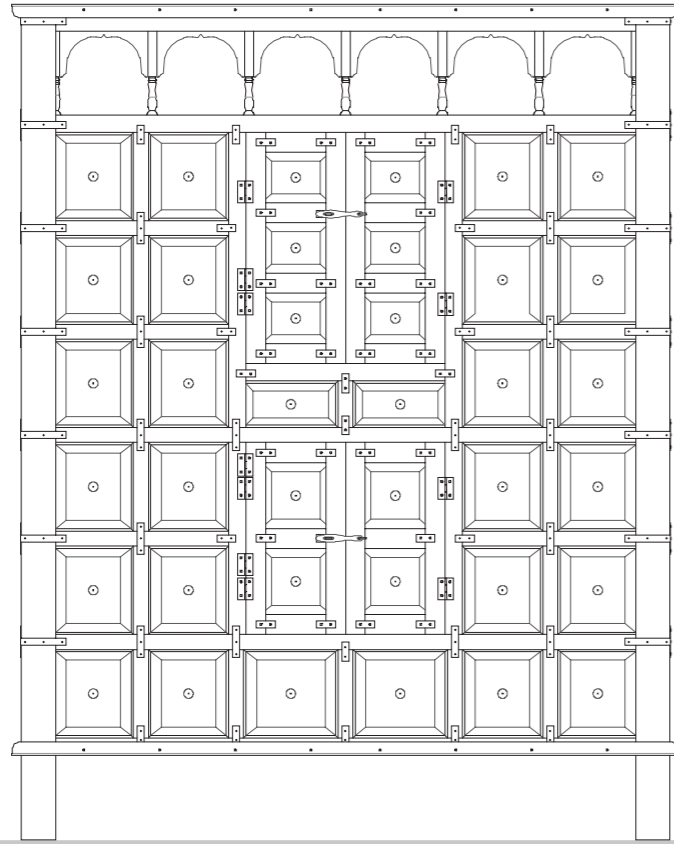

Front elevation

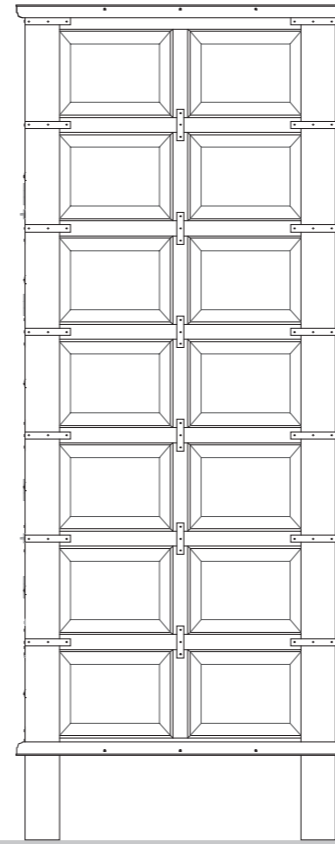

Side elevation

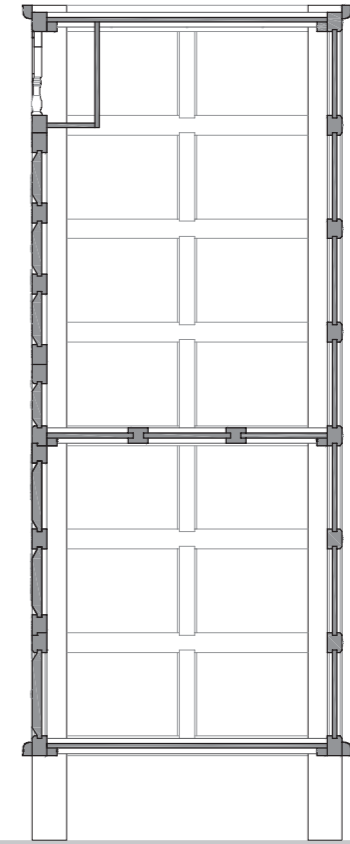

Section 1

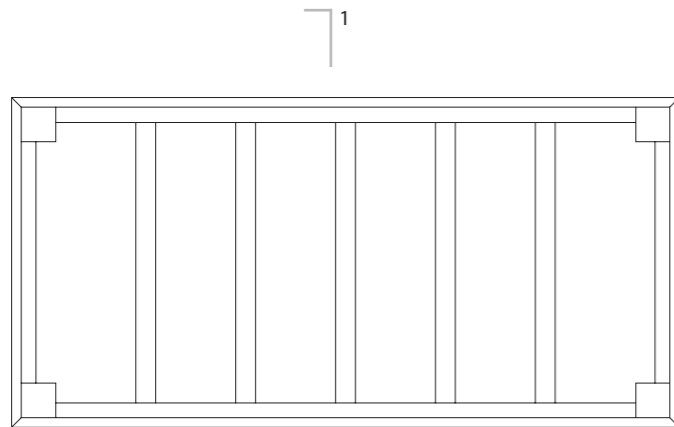

Plan (Top View)

Vernacular Furniture of Punjab

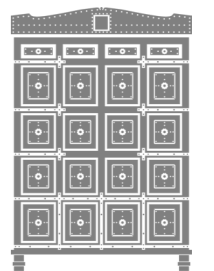

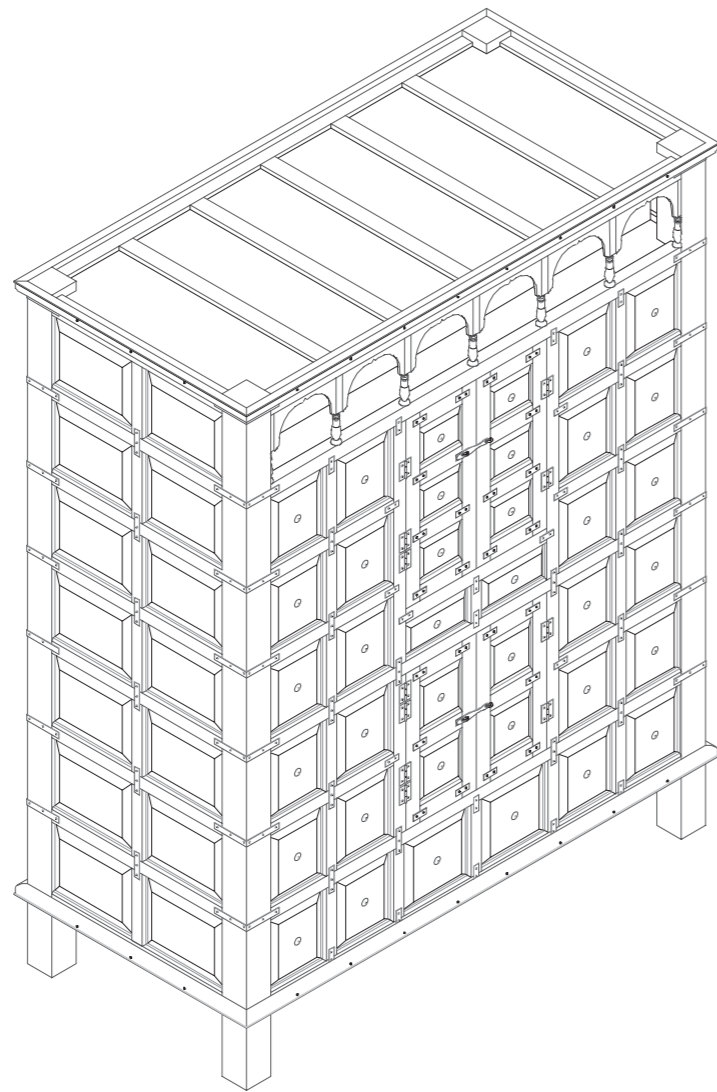

Isometric view

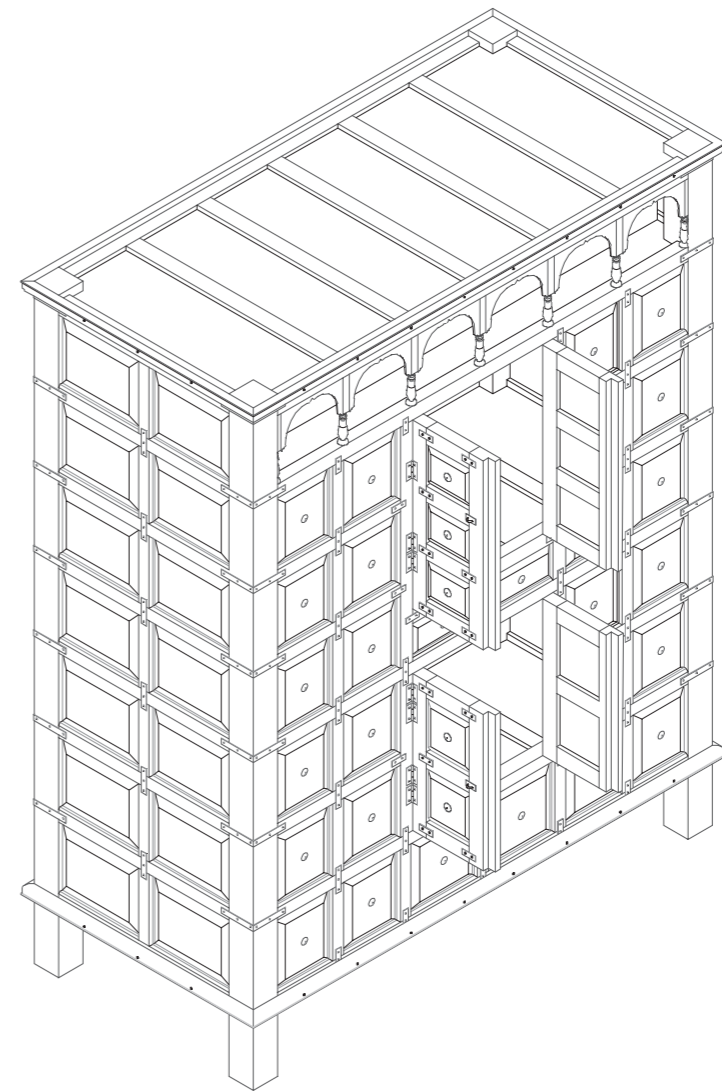

Isometric view (open)

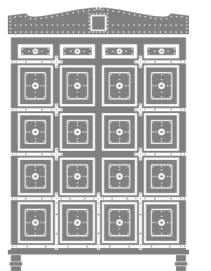

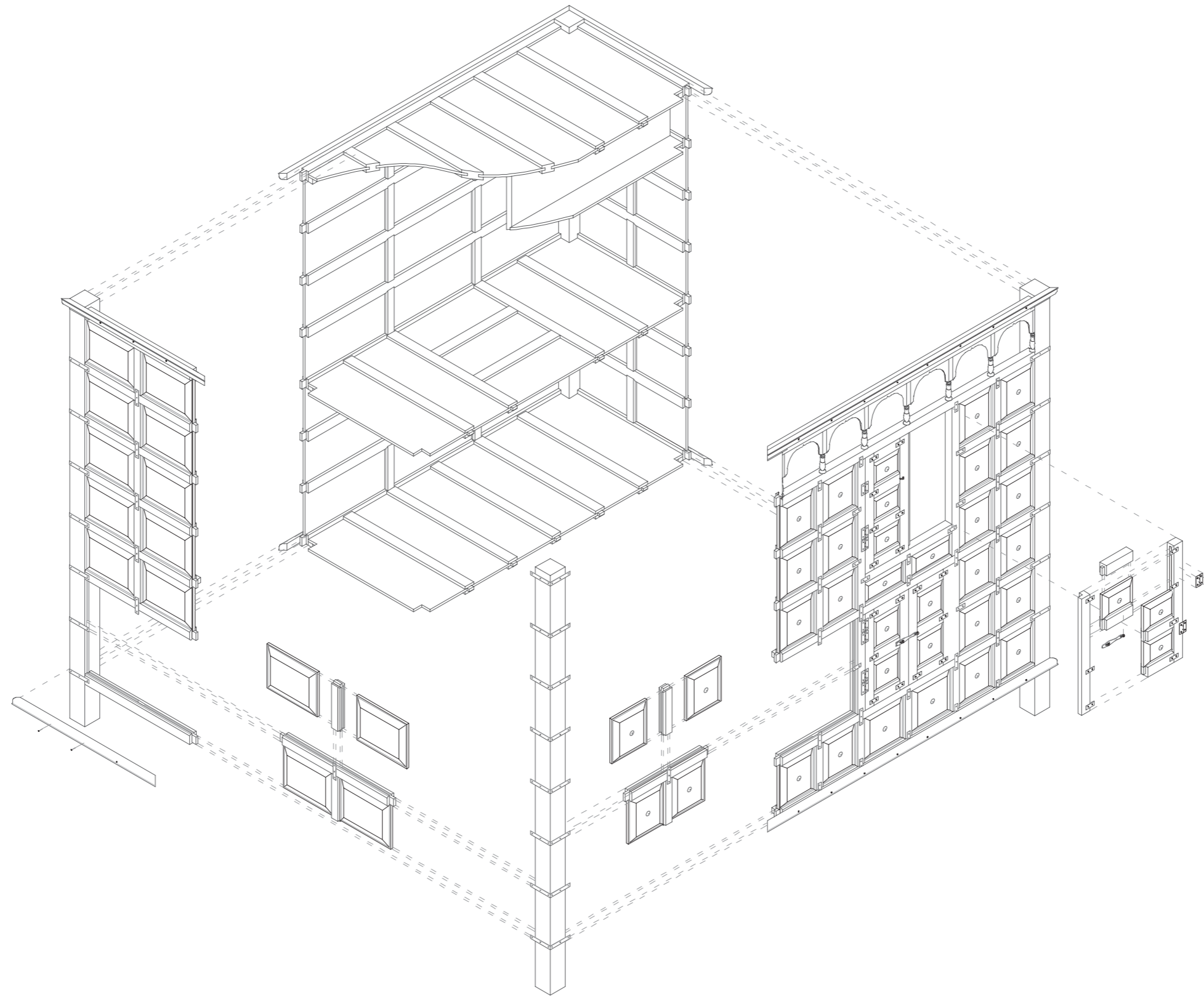

Exploded Isometric view

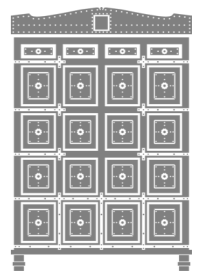

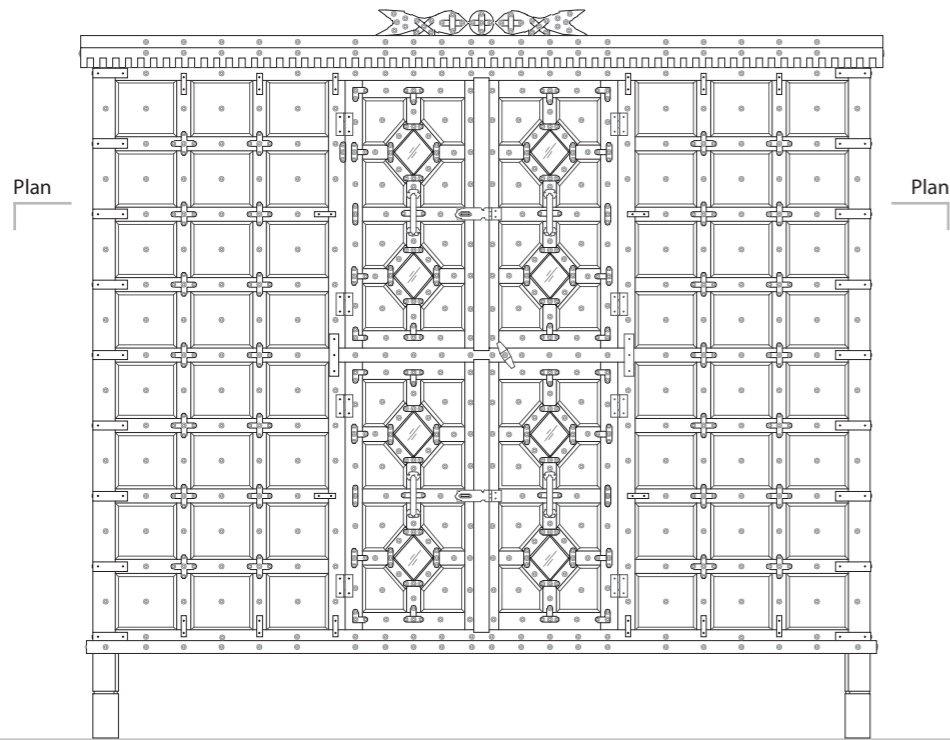

Front elevation

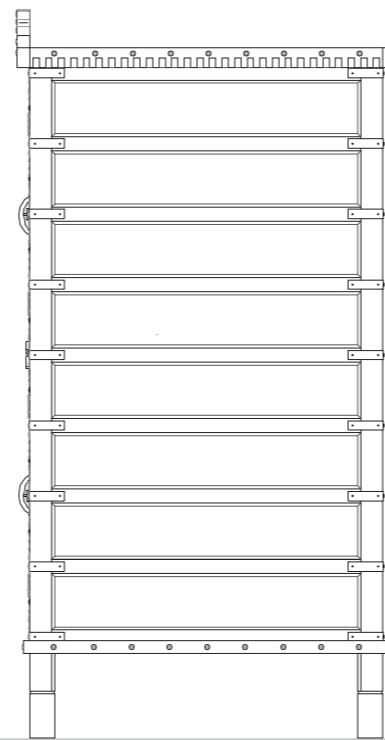

Side elevation

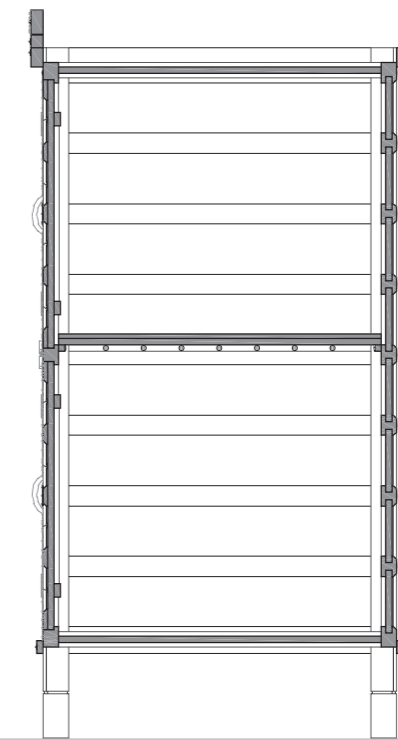

Section 1

Plan

Plan

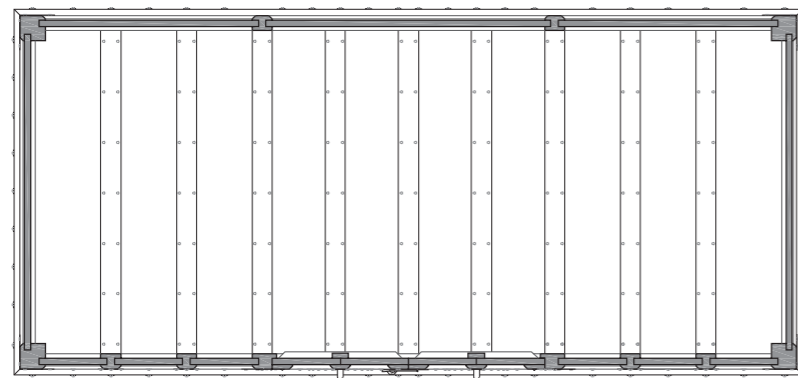

Plan

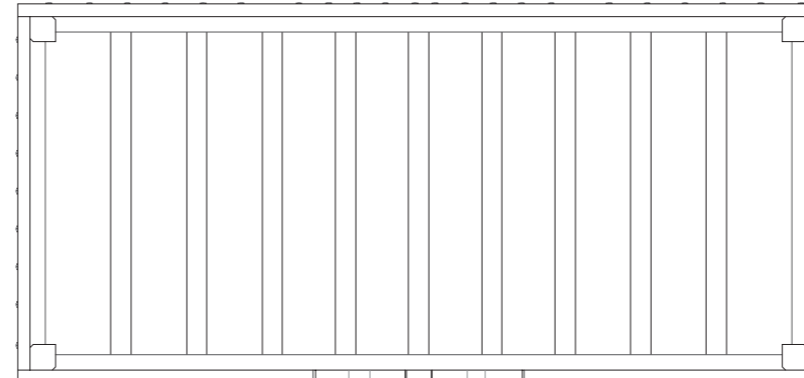

Plan (Top View)

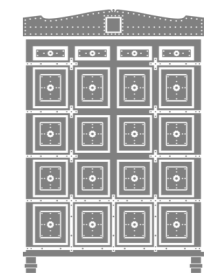

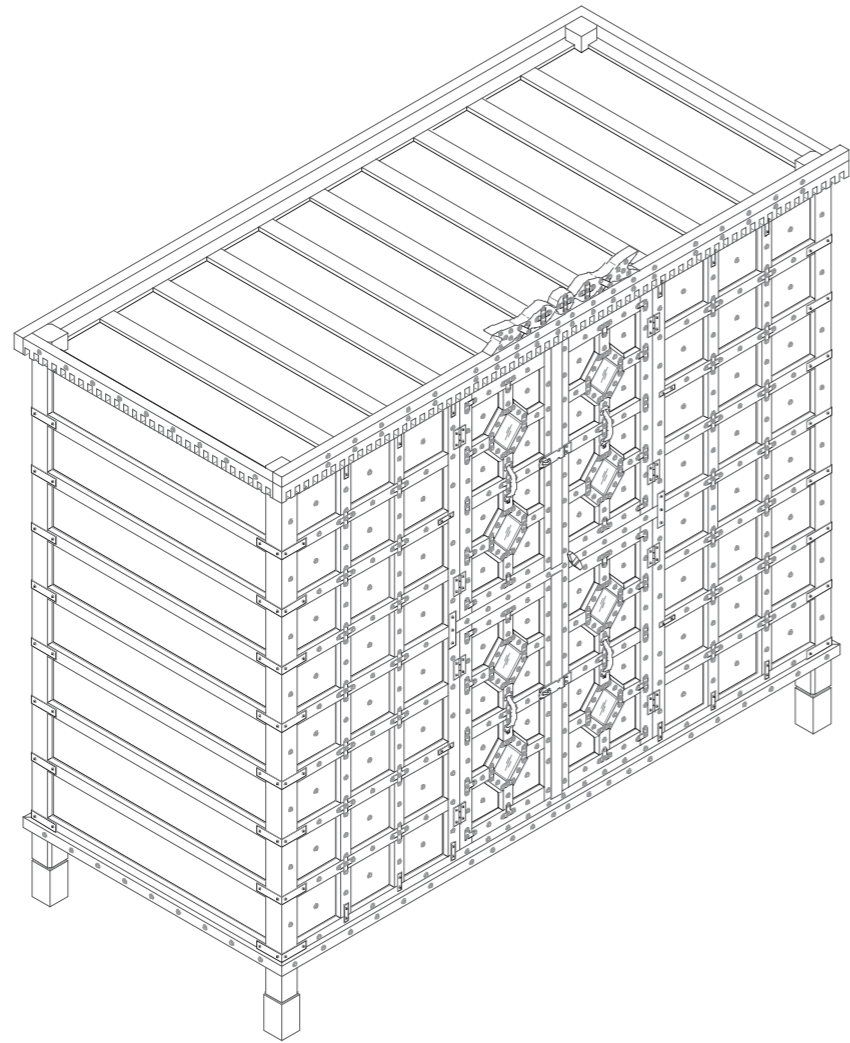

Isometric view

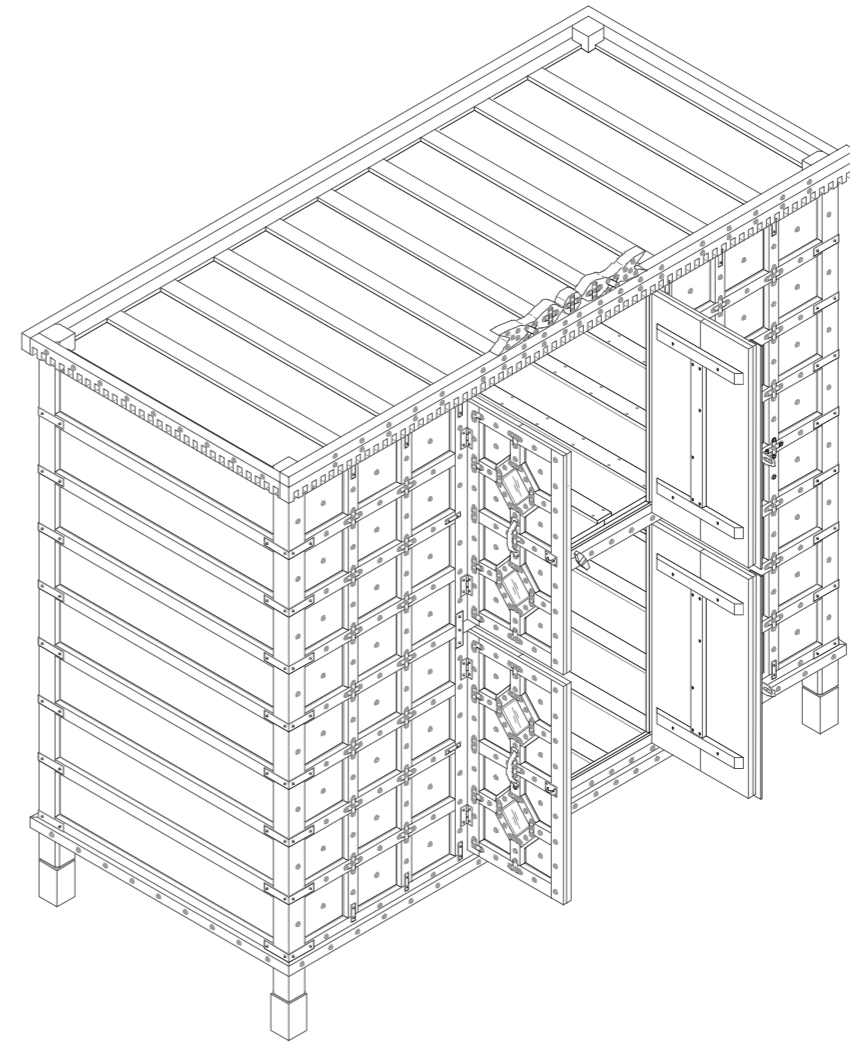

Isometric view (open)

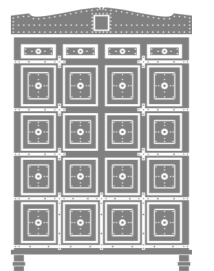

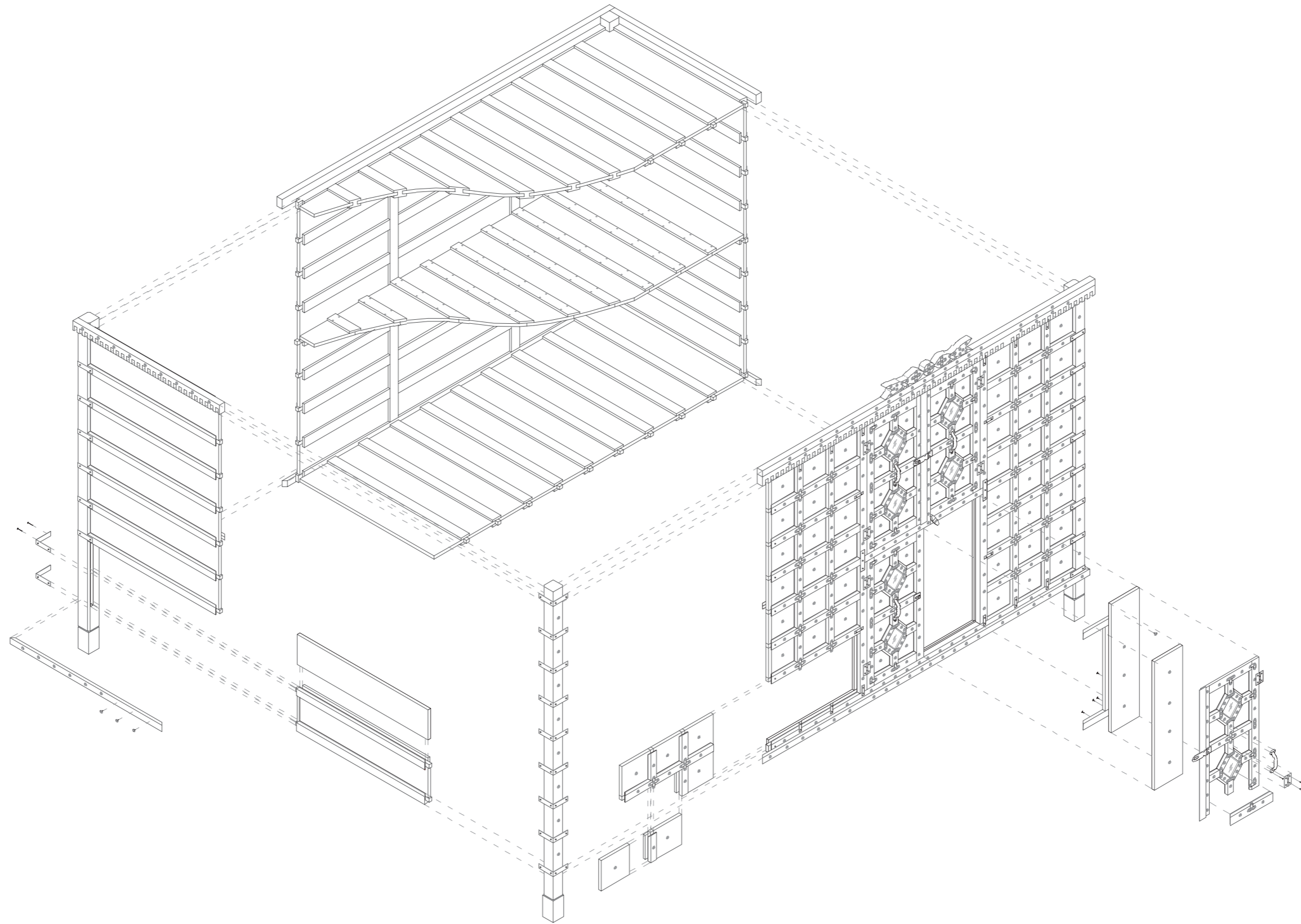

Exploded Isometric view

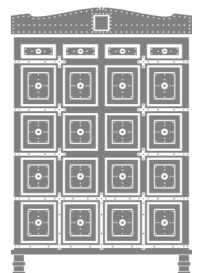

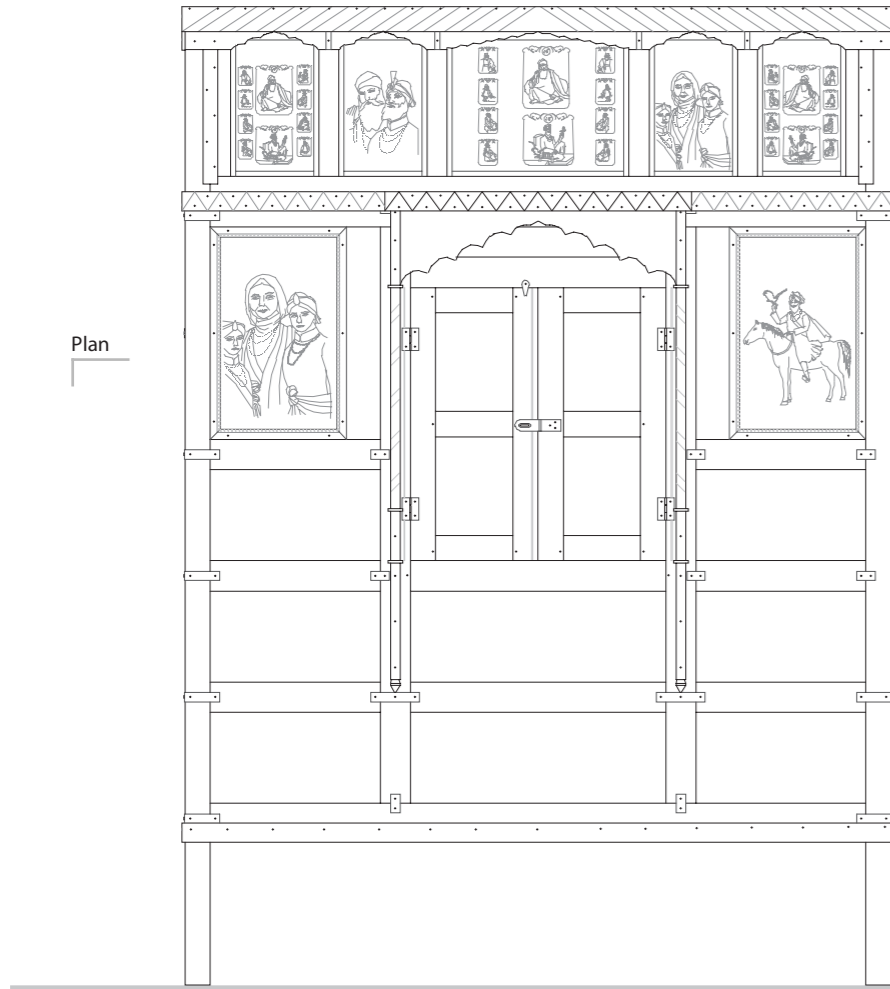

Front elevation

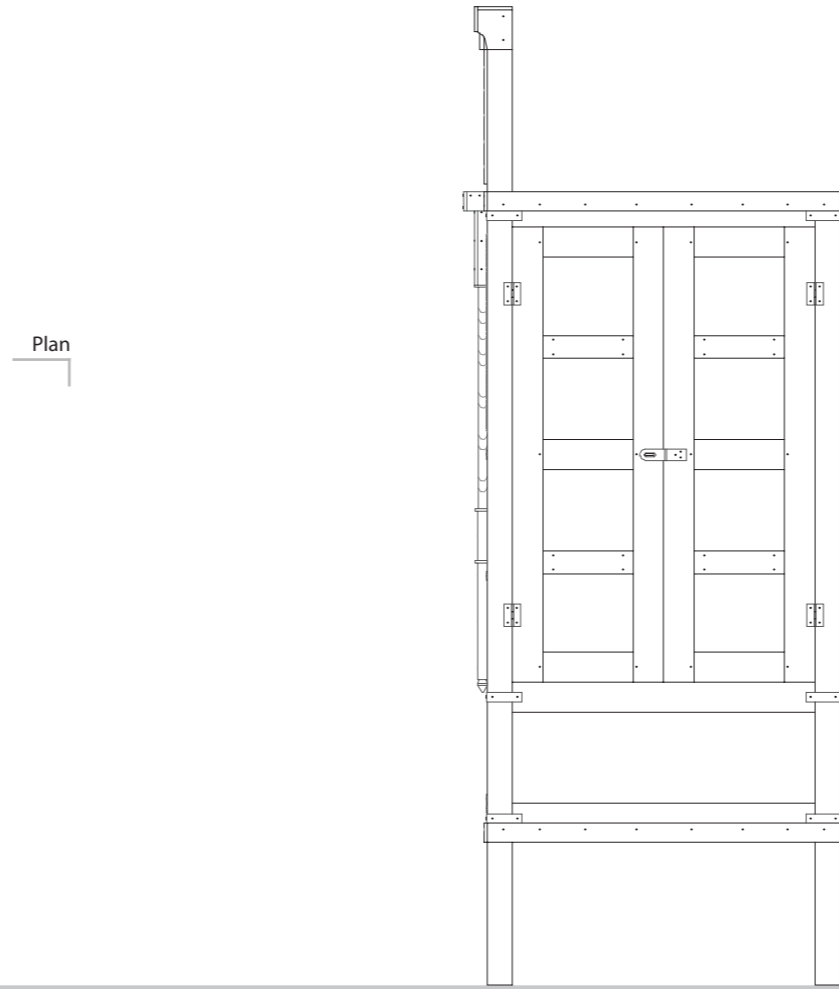

Side elevation

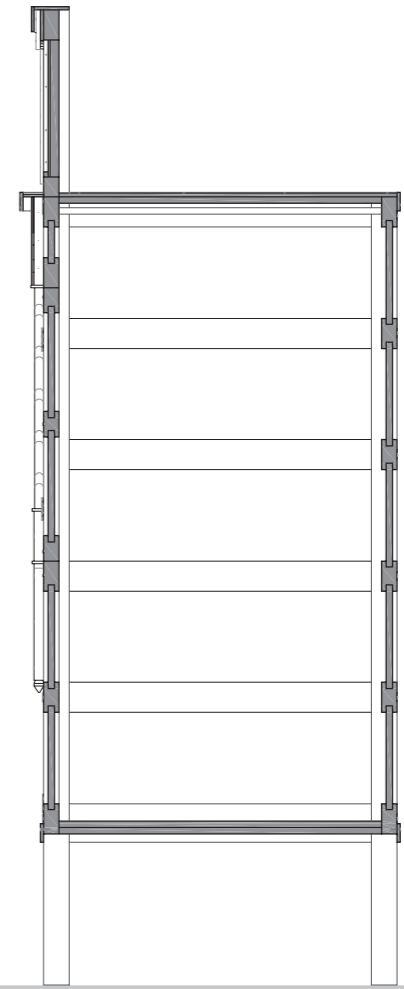

Section 1

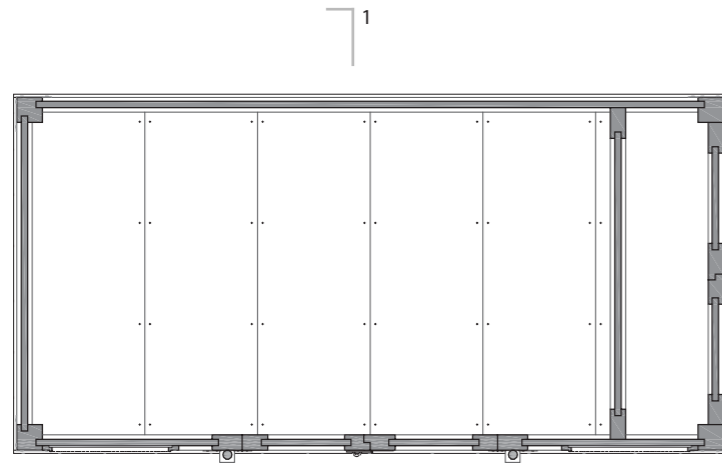

Plan (Top View)

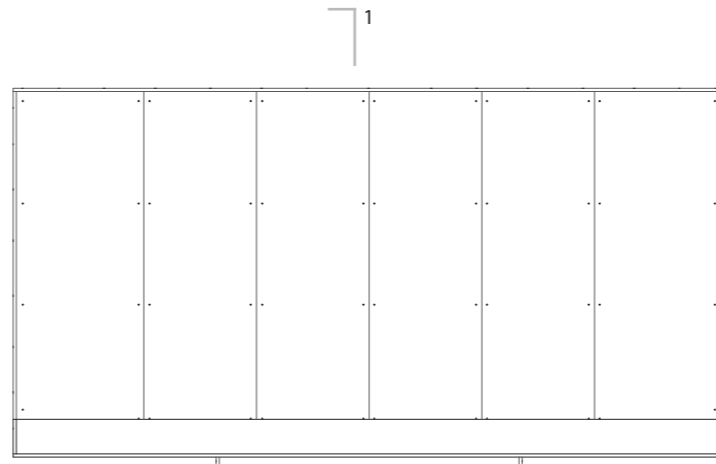

Plan (Top View)

Vernacular Furniture of Punjab

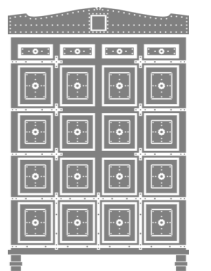

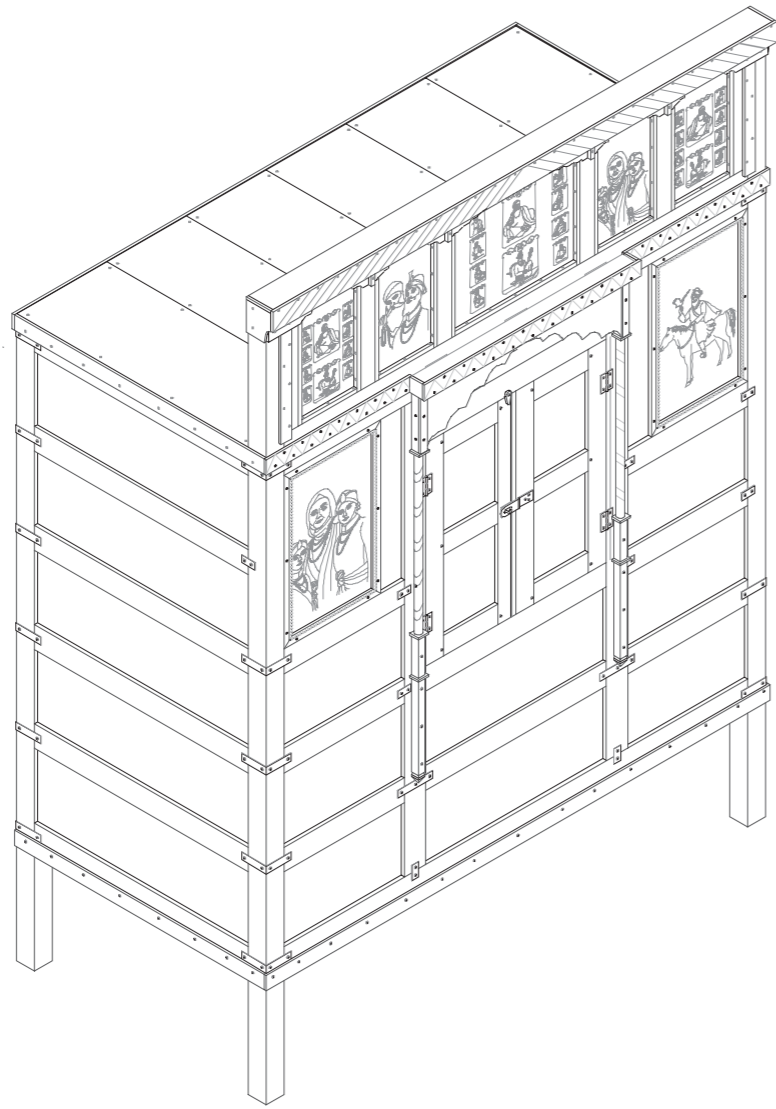

Isometric view



Isometric view (open)

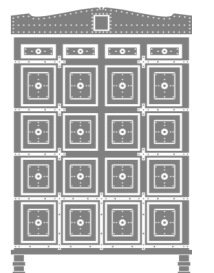

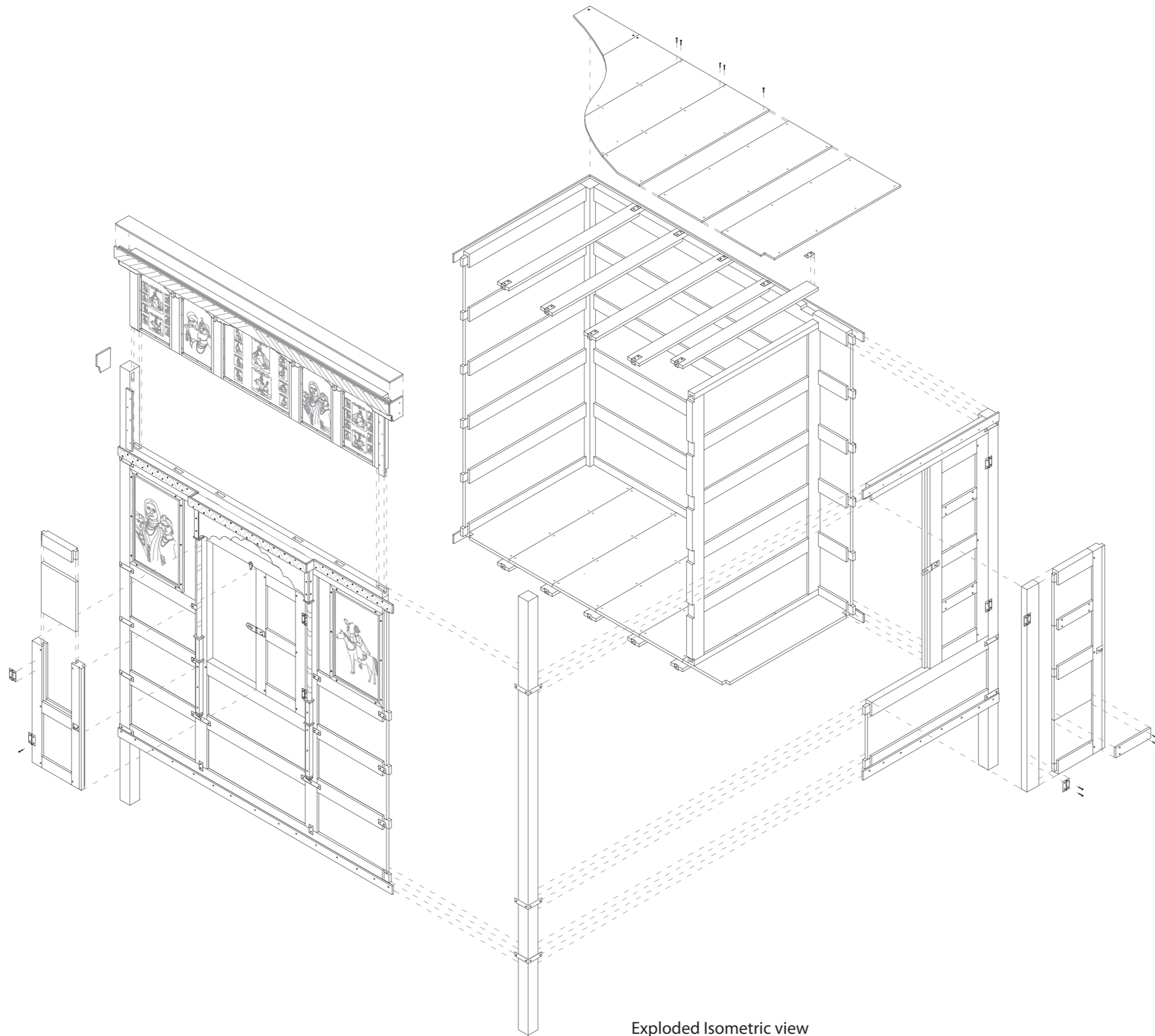

Exploded Isometric view

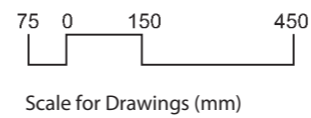

Vernacular Furniture of Punjab

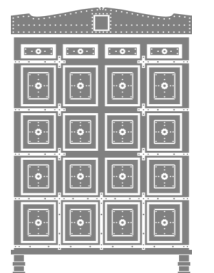

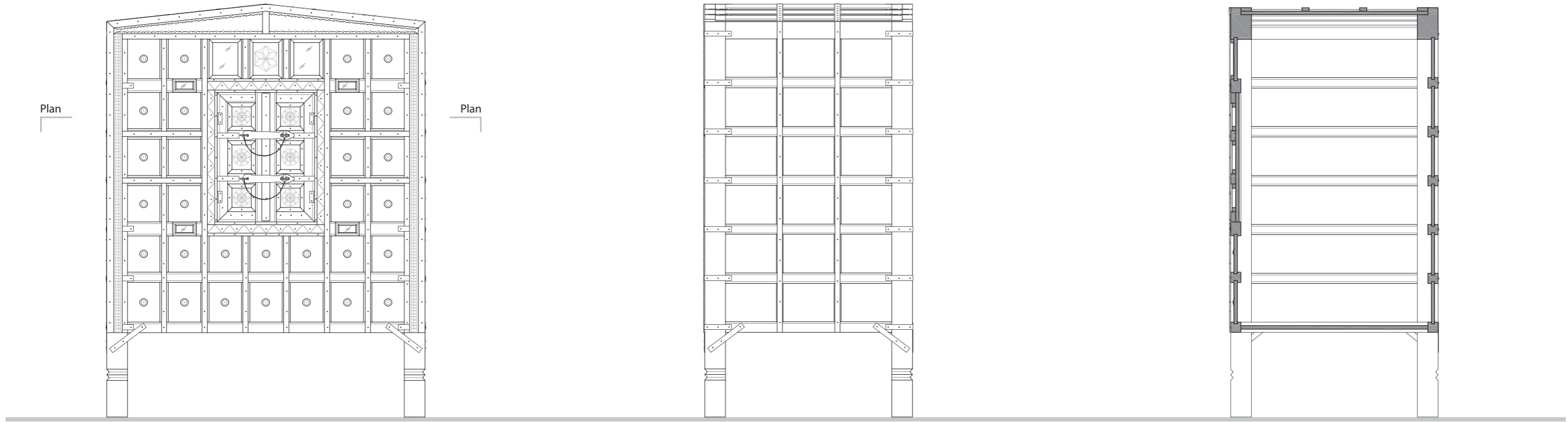

Front elevation

Side elevation

Section 1

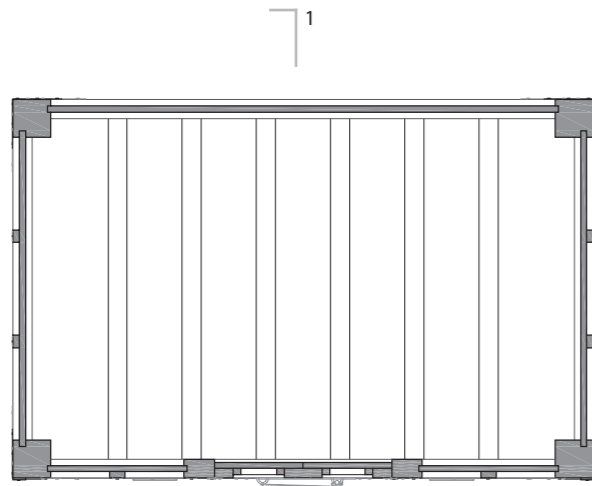

Plan

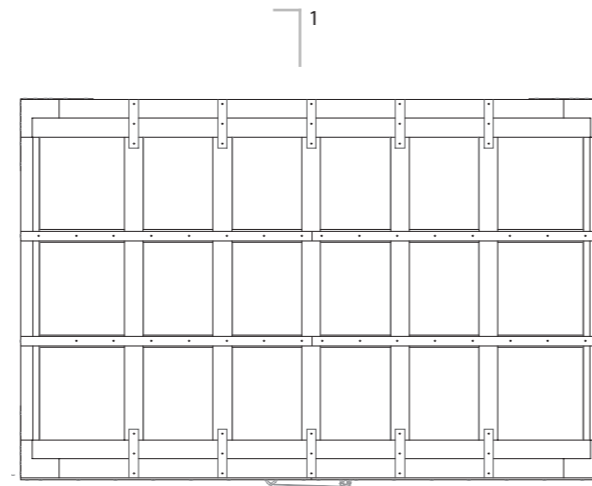

Plan (Top View)

Vernacular Furniture of Punjab

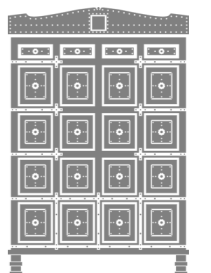

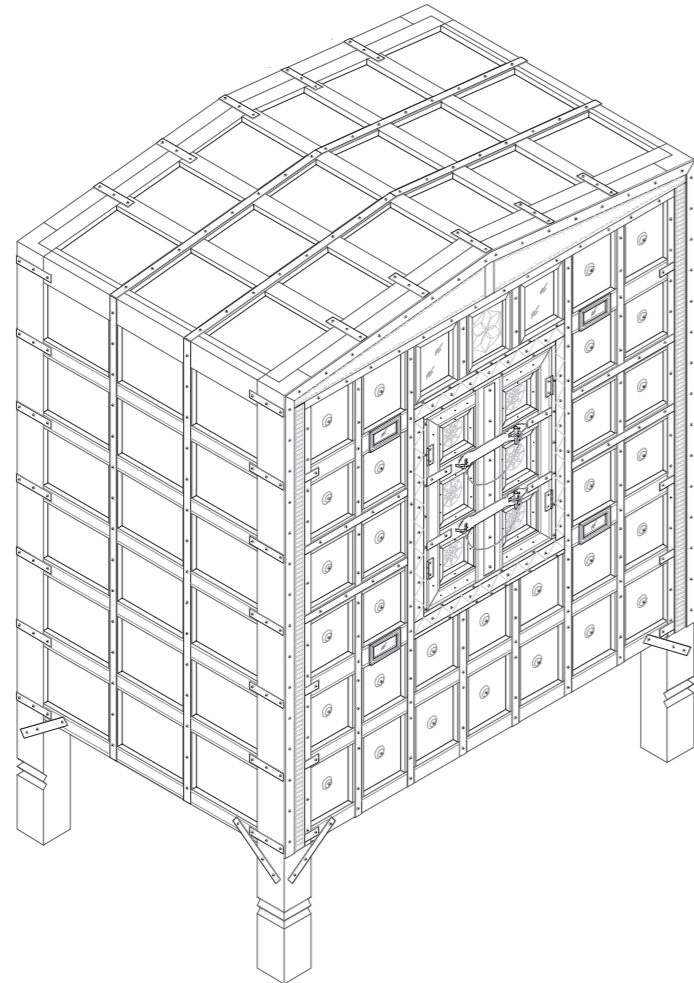

Isometric view

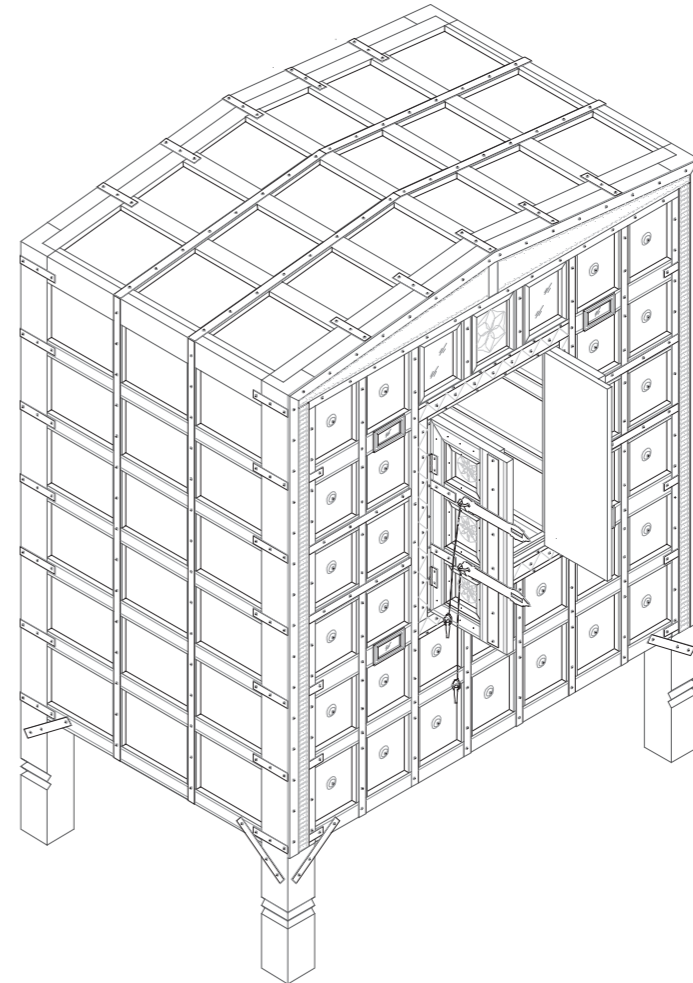

Isometric view (open)

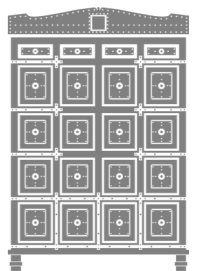

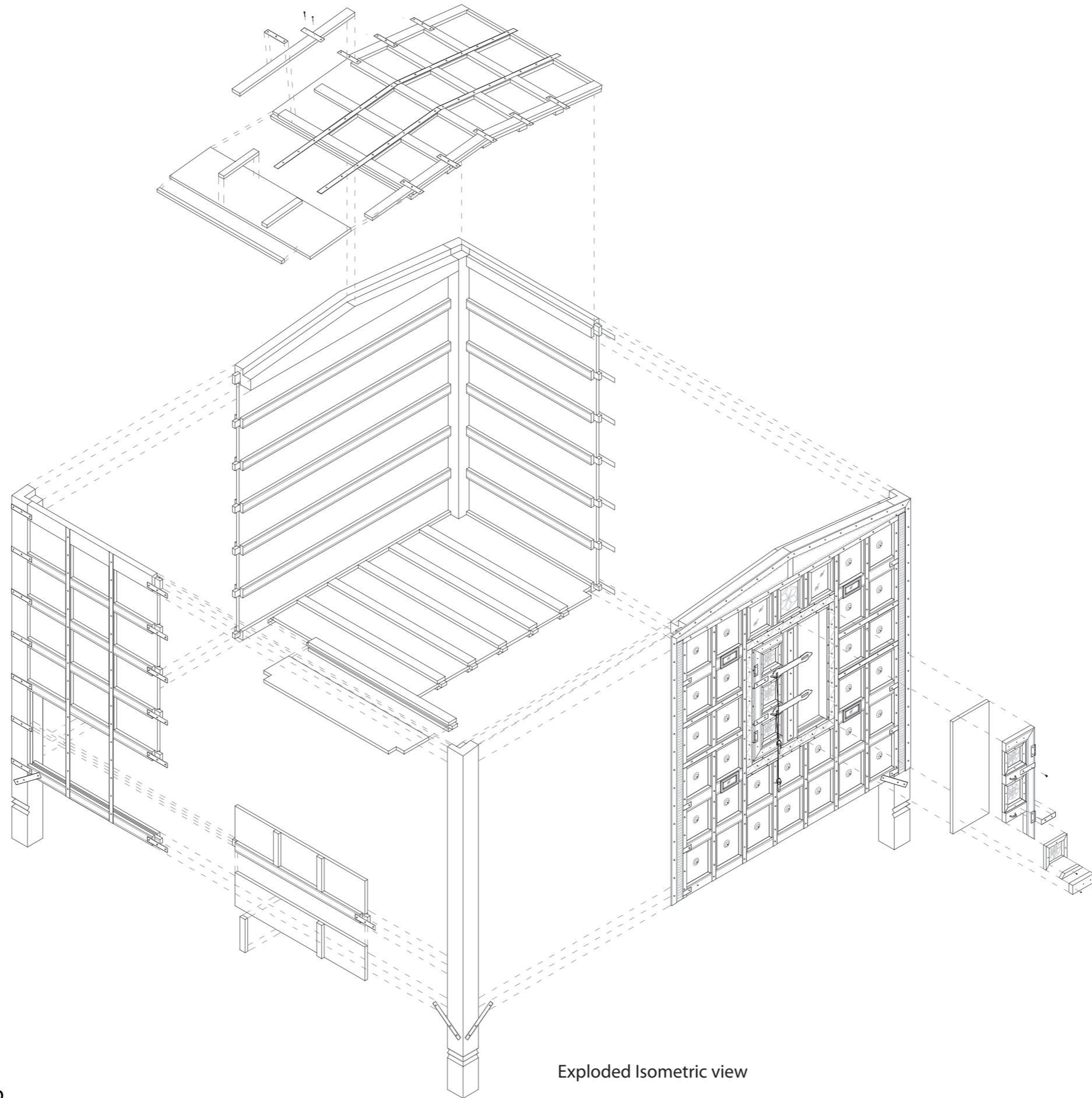

Exploded Isometric view

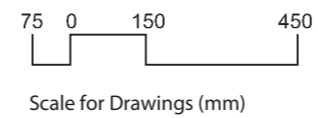

Vernacular Furniture of Punjab

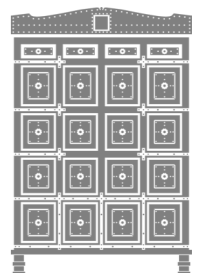

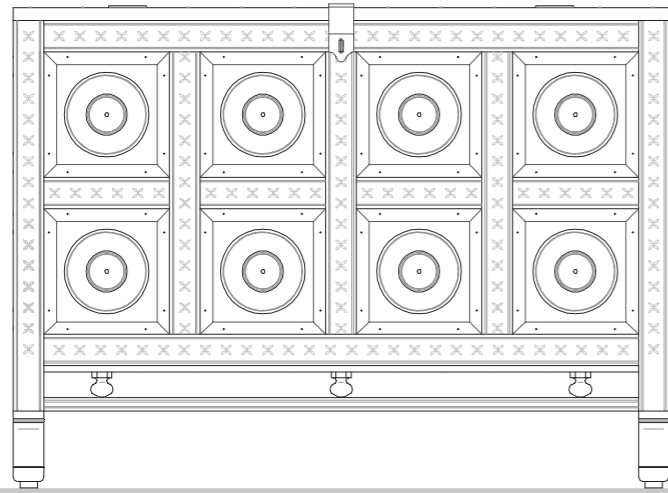

Front elevation

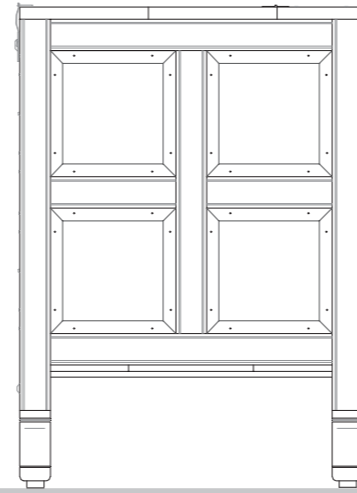

Side elevation

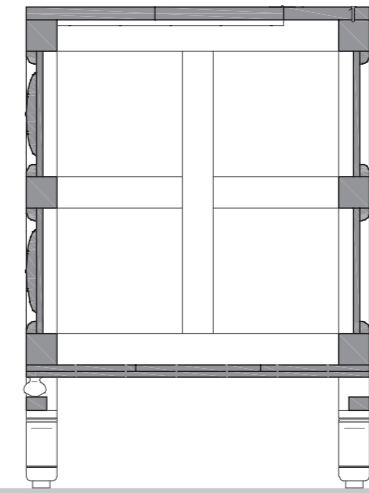

Section 1

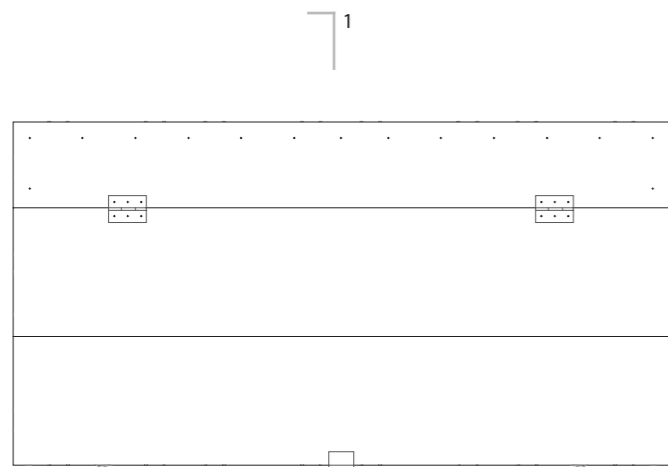

Plan (Top View)

Vernacular Furniture of Punjab

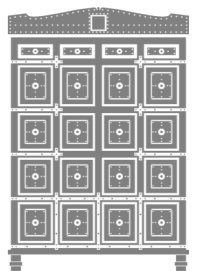

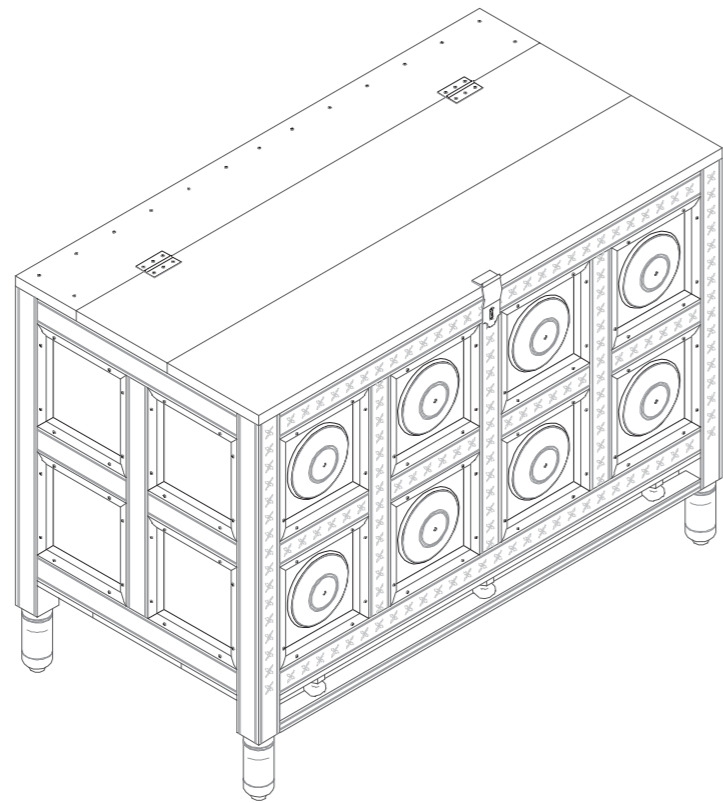

Isometric view

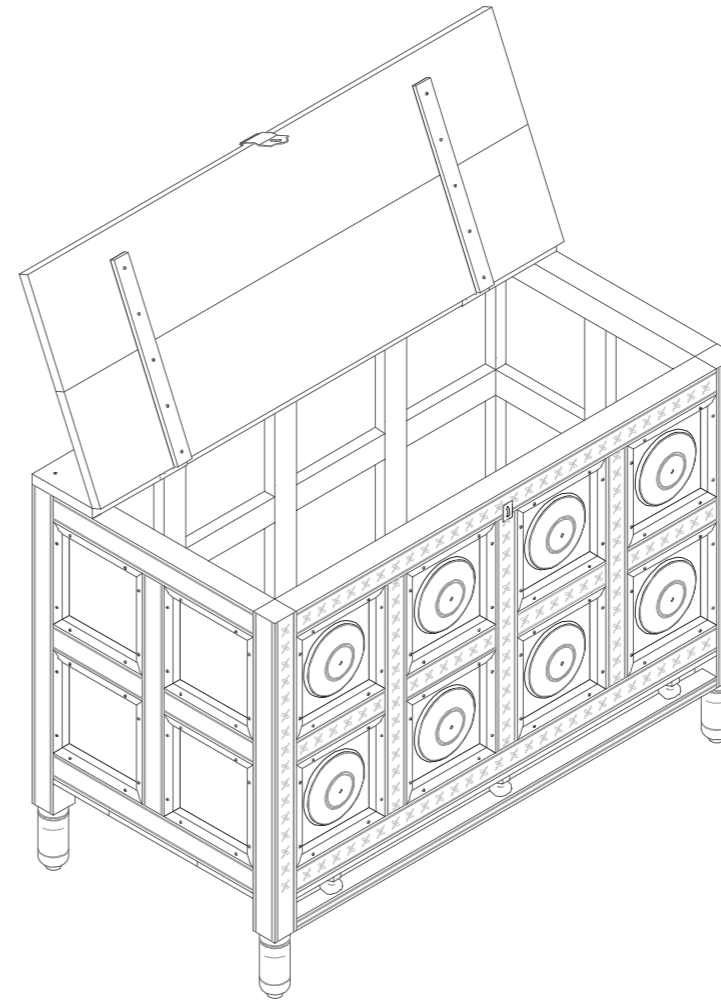

Isometric view (open)

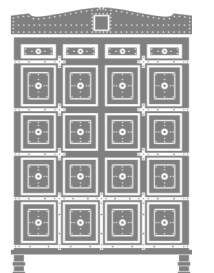

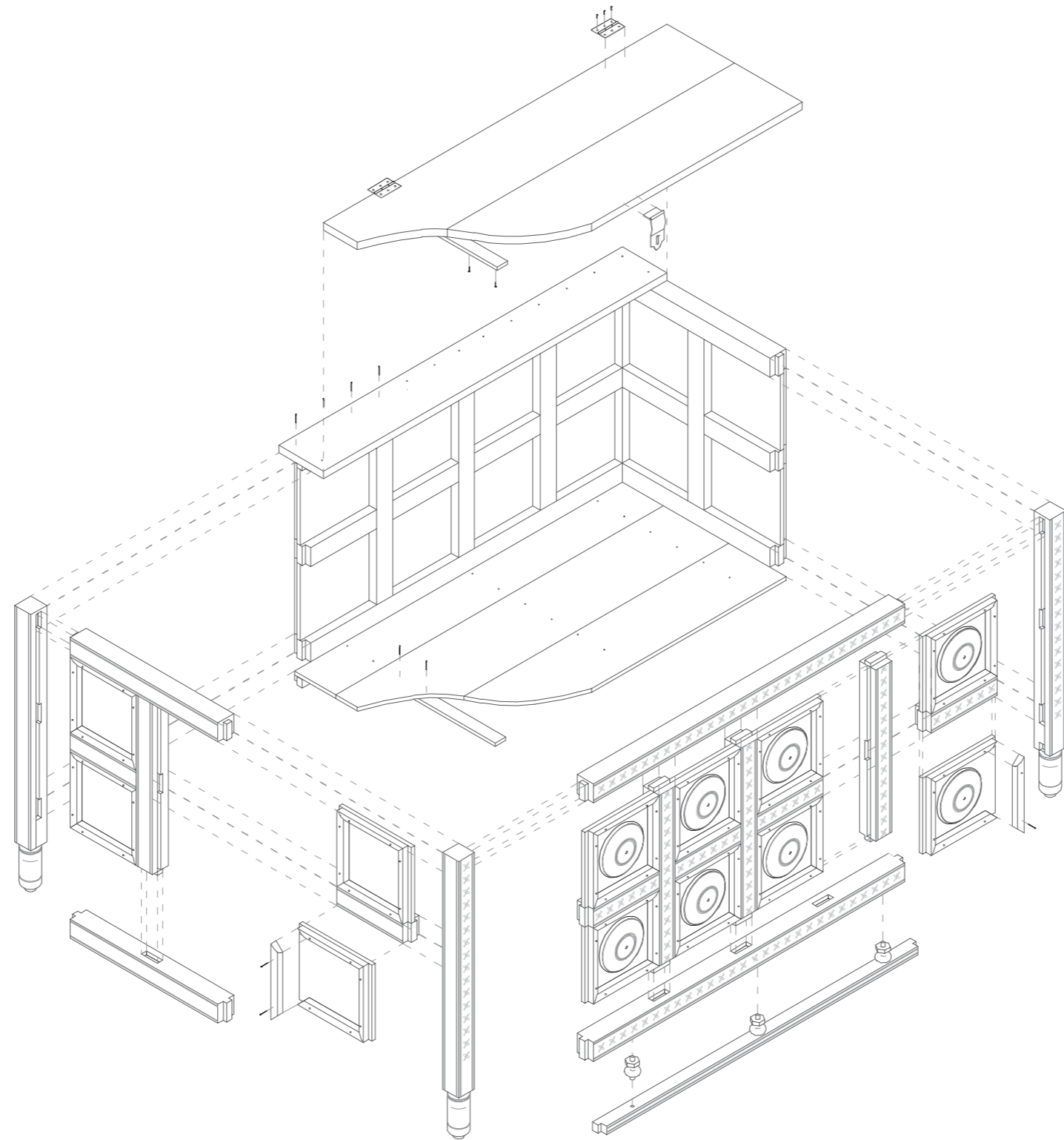

Exploded Isometric view

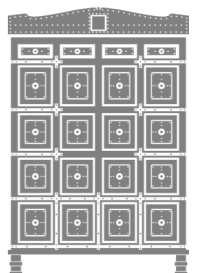

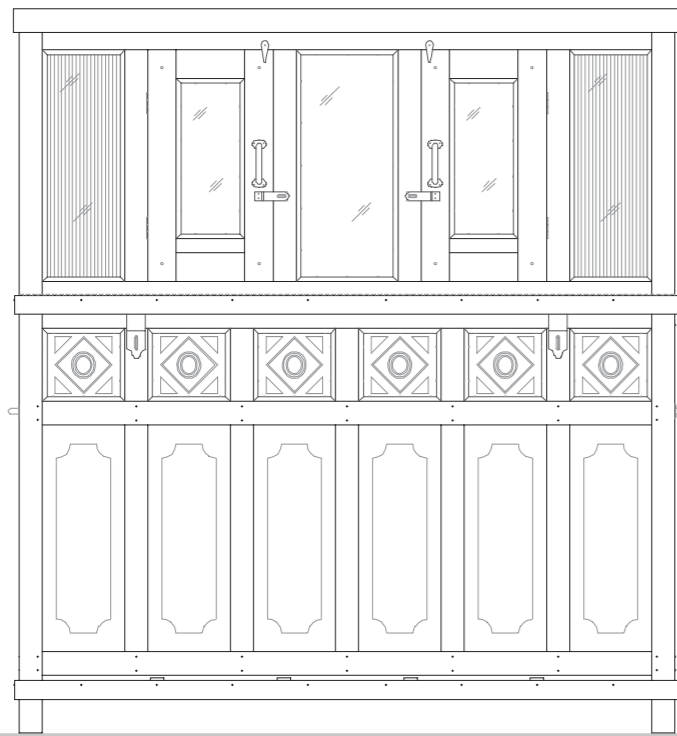

Front elevation

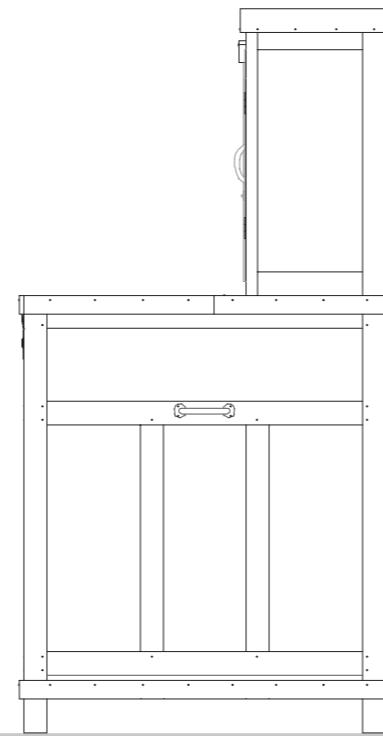

Side elevation

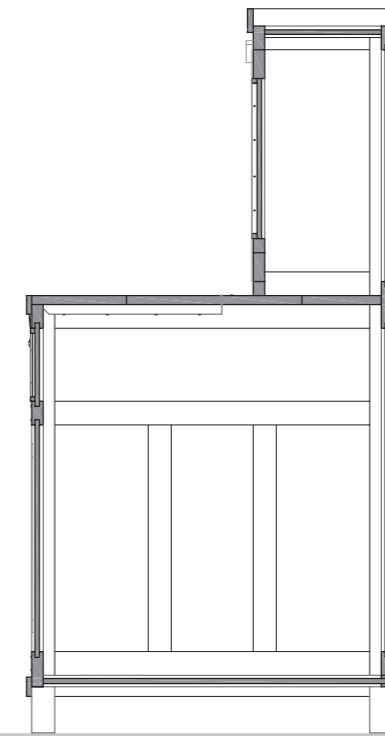

Section 1

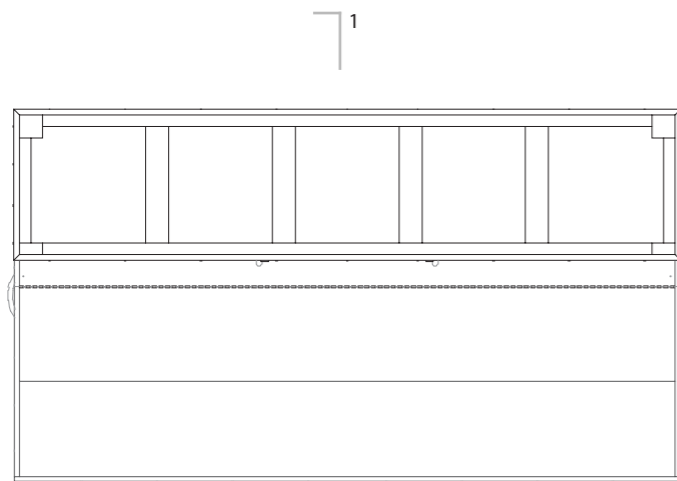

Plan (Top View)

Vernacular Furniture of Punjab

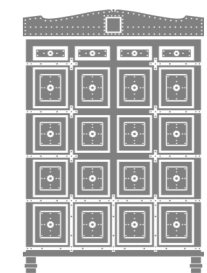

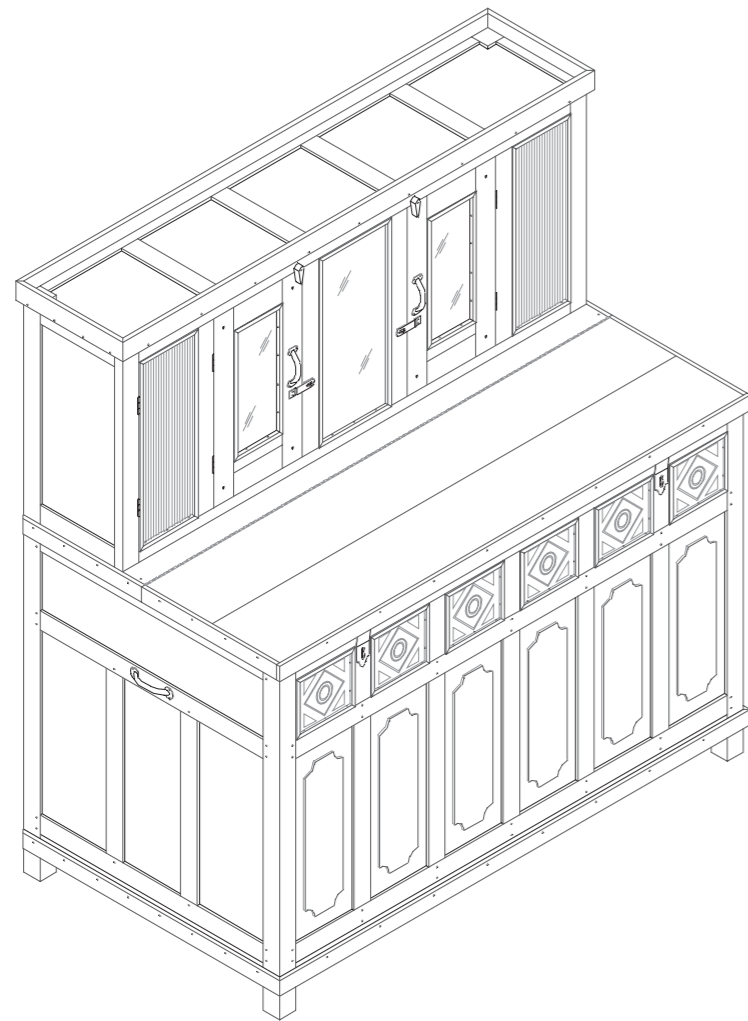

Isometric view

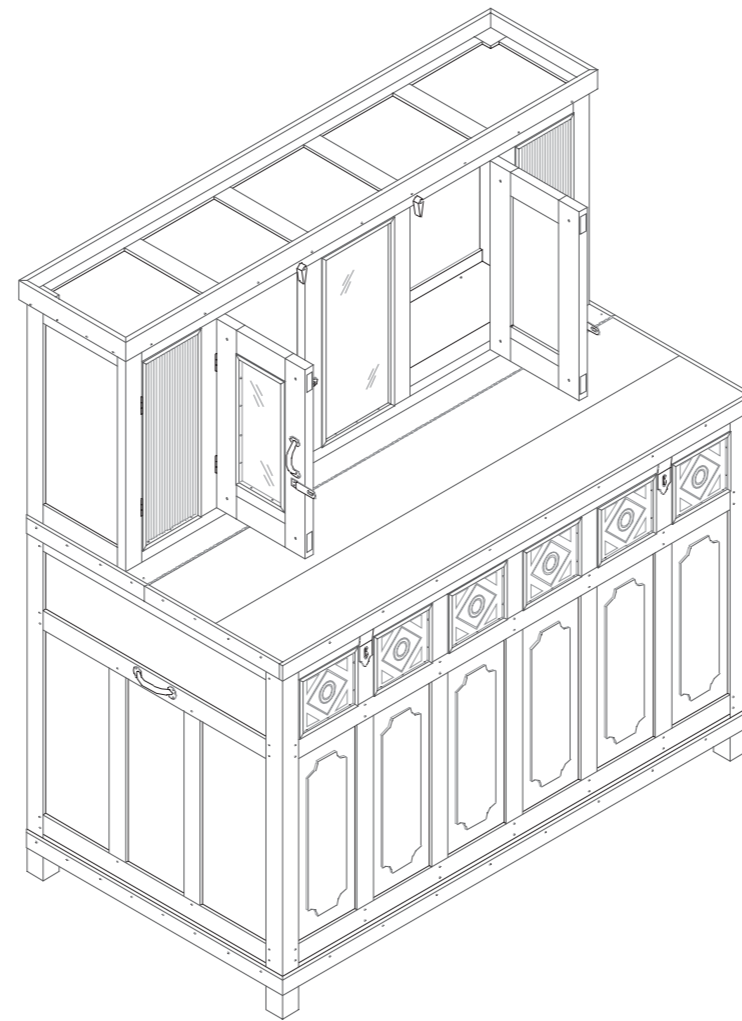

Isometric view (open)

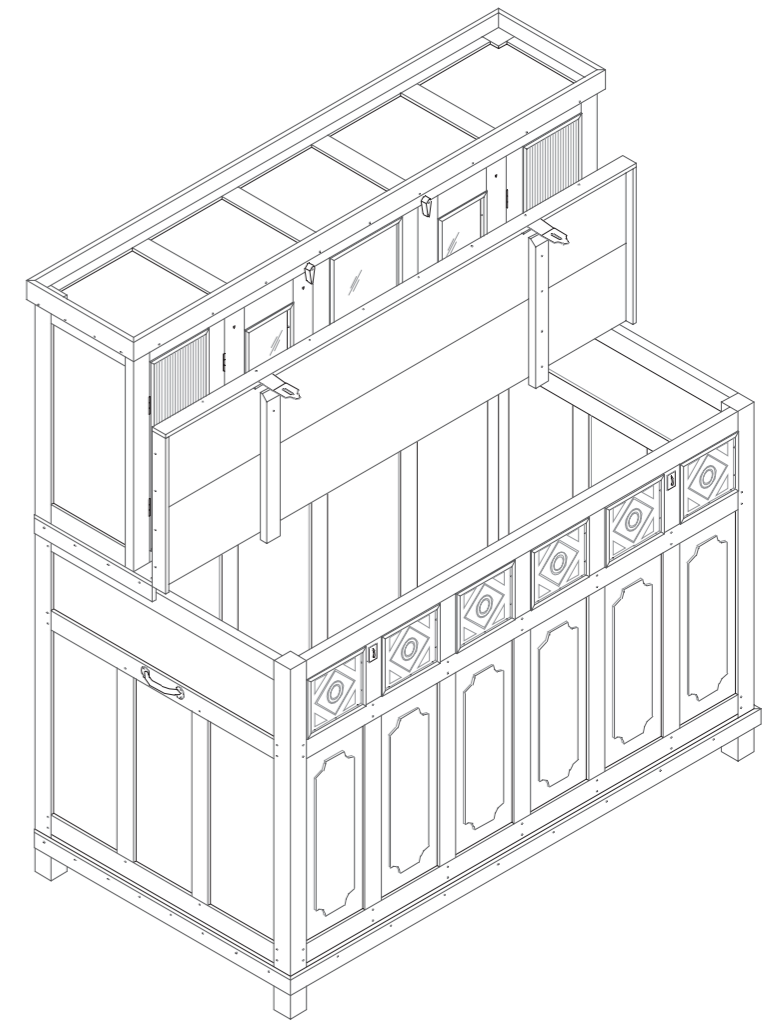

Isometric view (open)

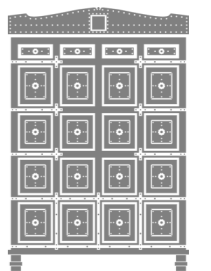

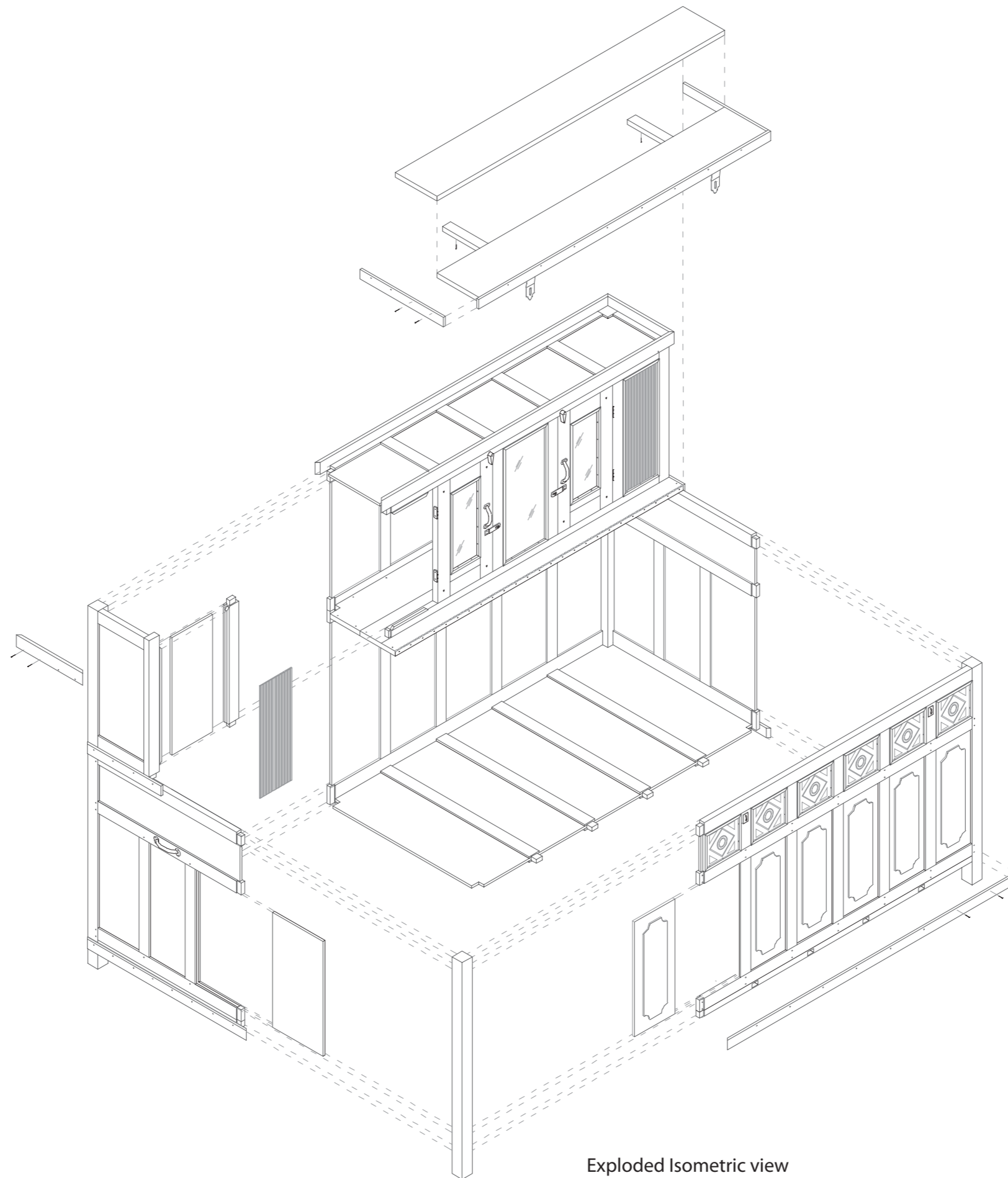

Exploded Isometric view

100 0 200 600

Scale for Drawings (mm)

Vernacular Furniture of Punjab



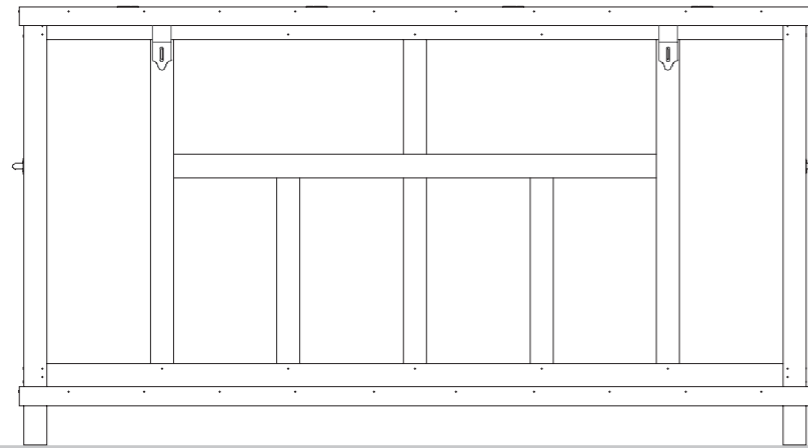

Front elevation

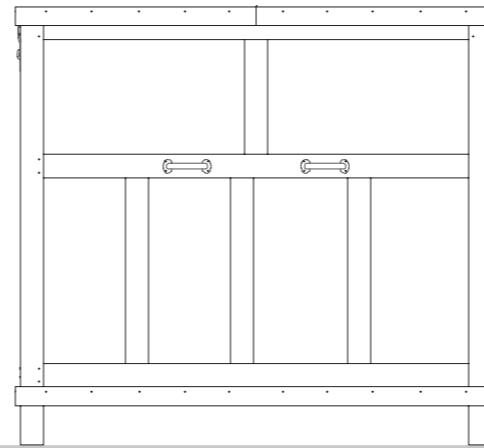

Side elevation

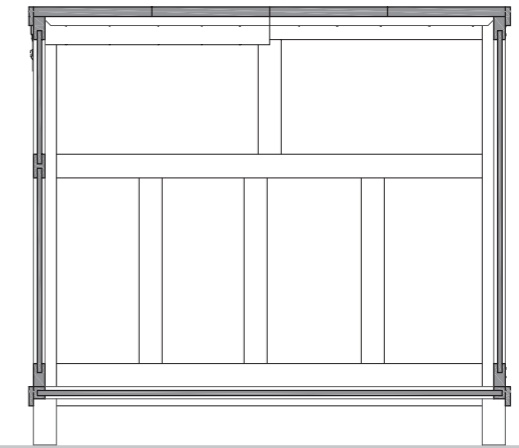

Section 1

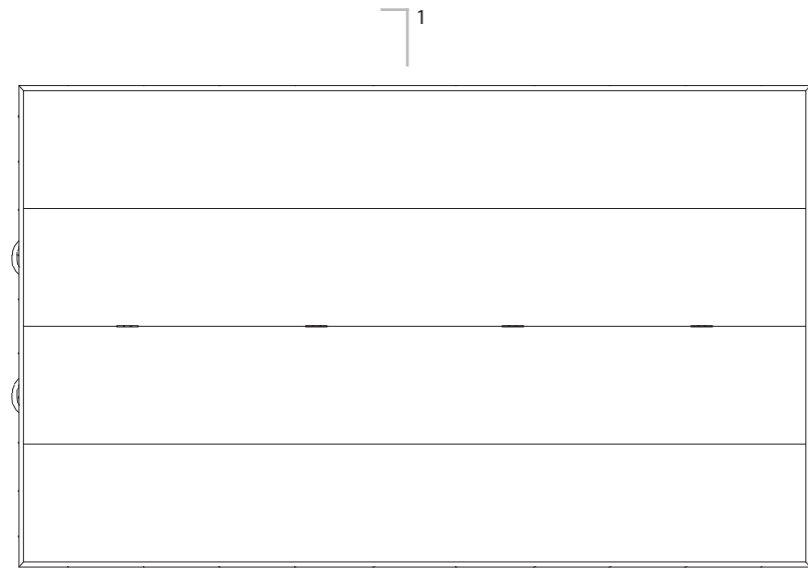

Plan (Top View)

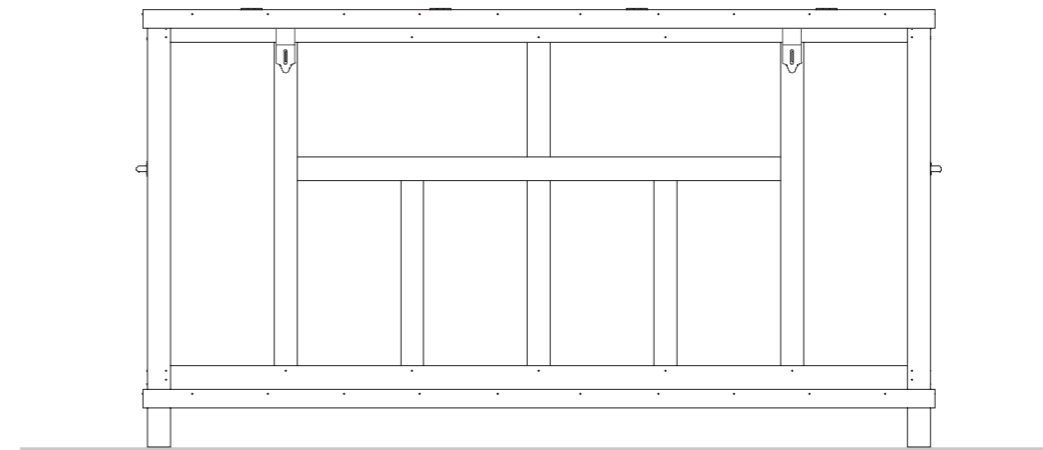

Back elevation

Vernacular Furniture of Punjab

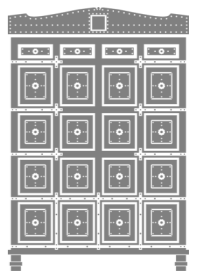

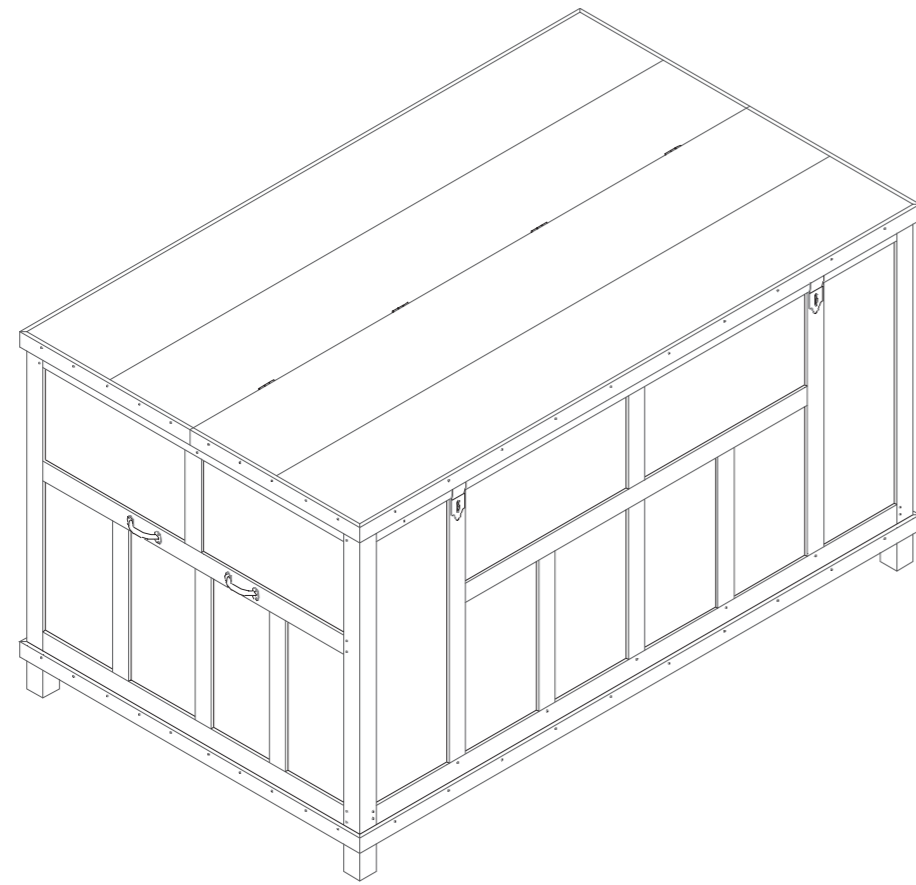

Isometric view

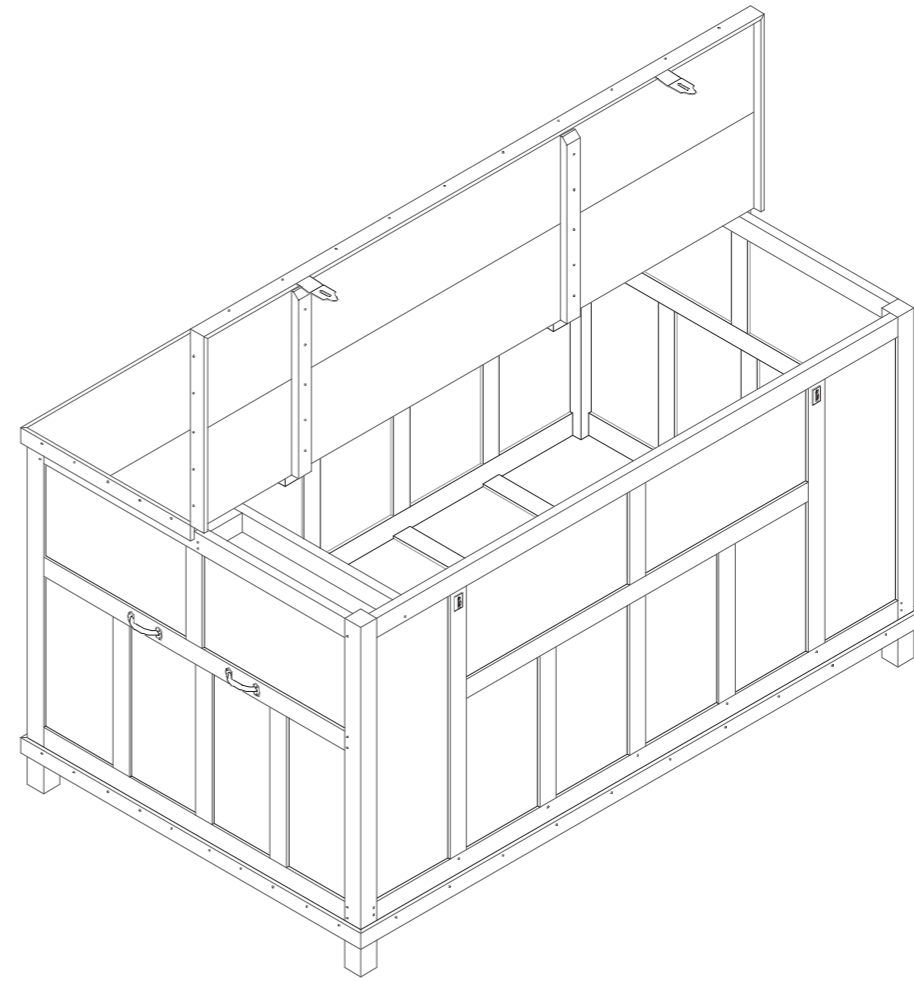

Isometric view (open)

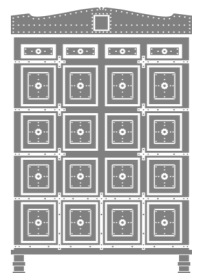

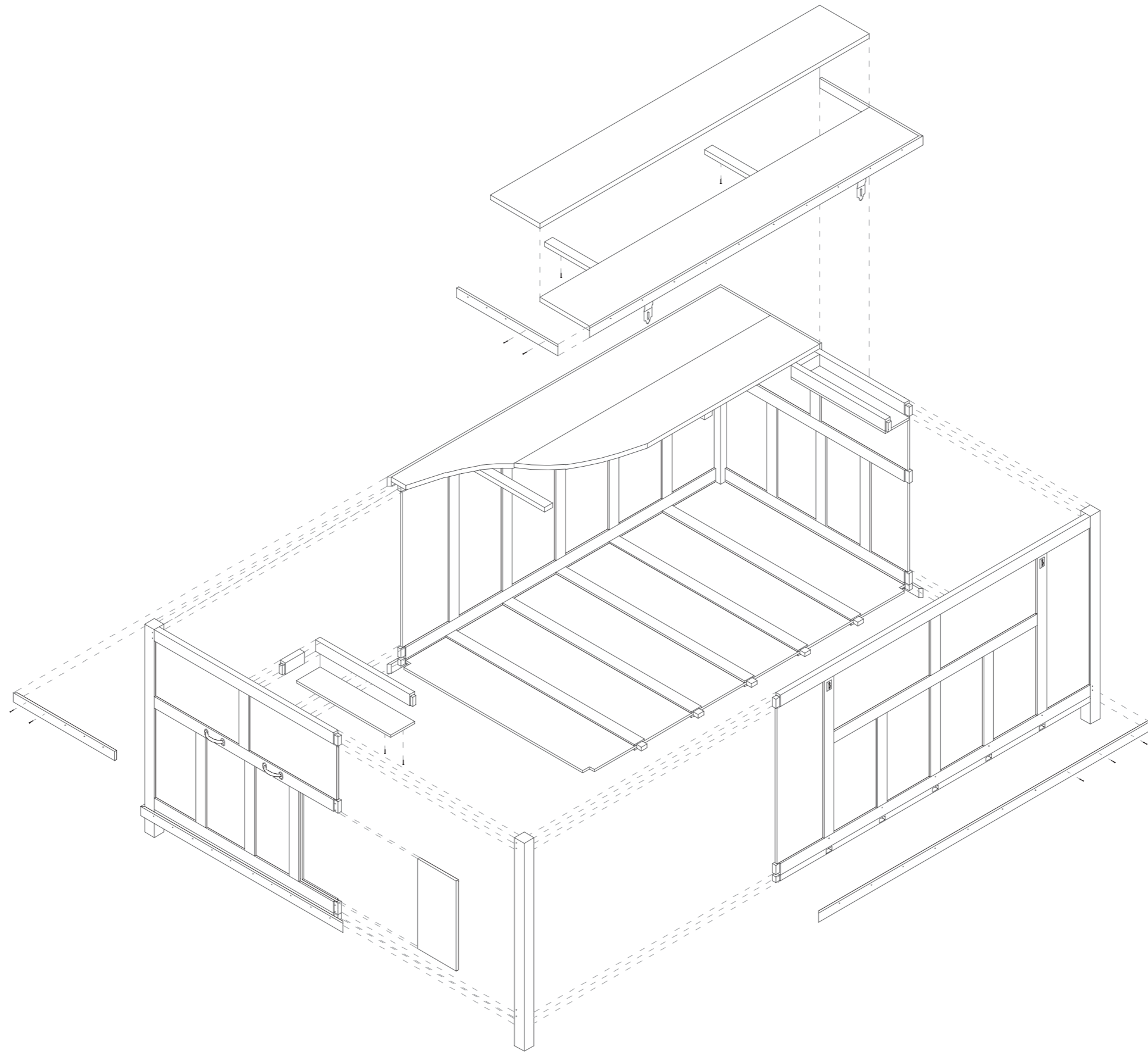

Exploded Isometric view

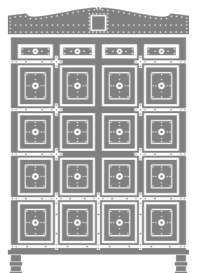

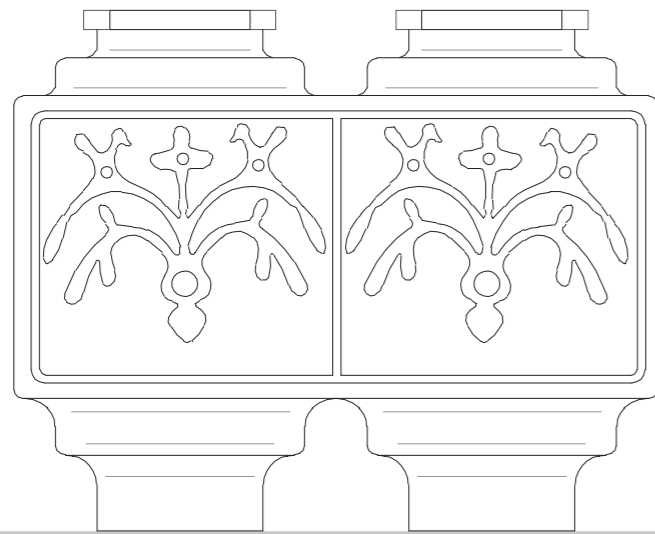

Front elevation

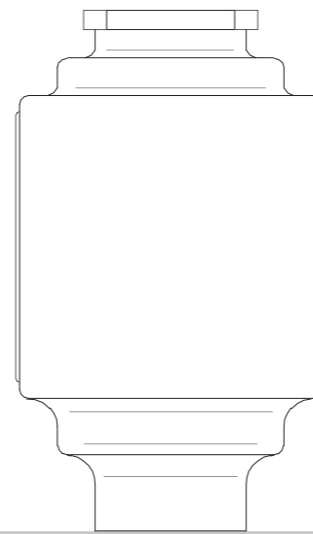

Side elevation

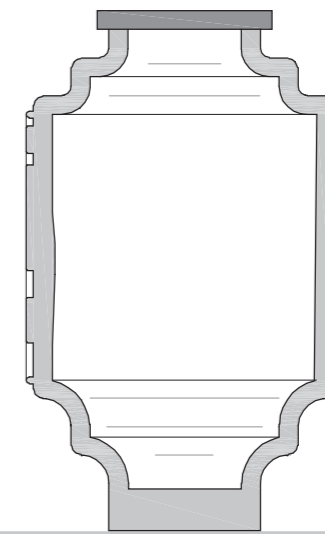

Section 1

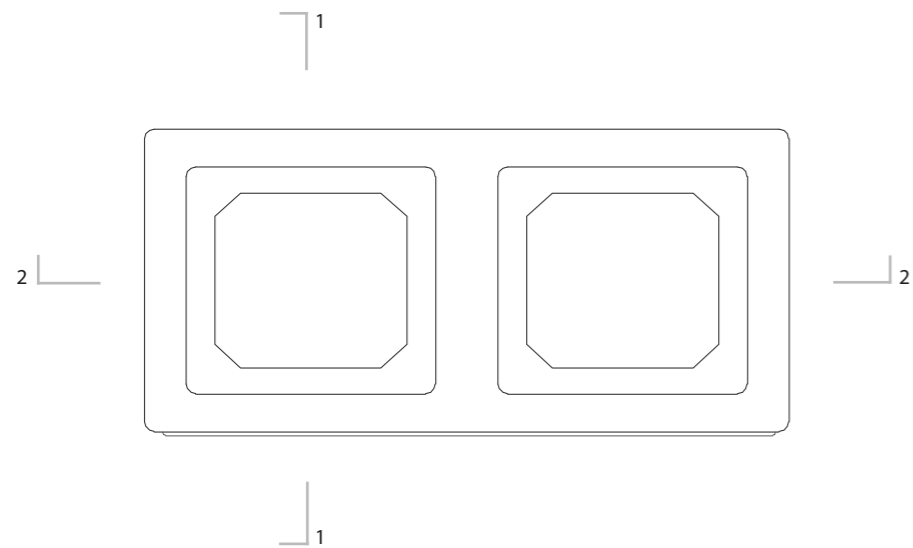

Plan (Top View)

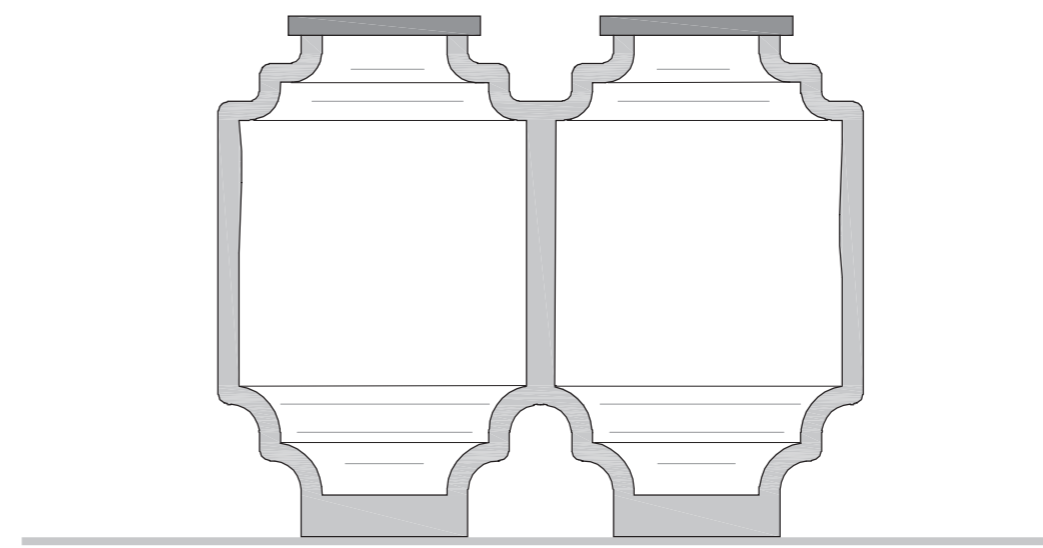

Section 2



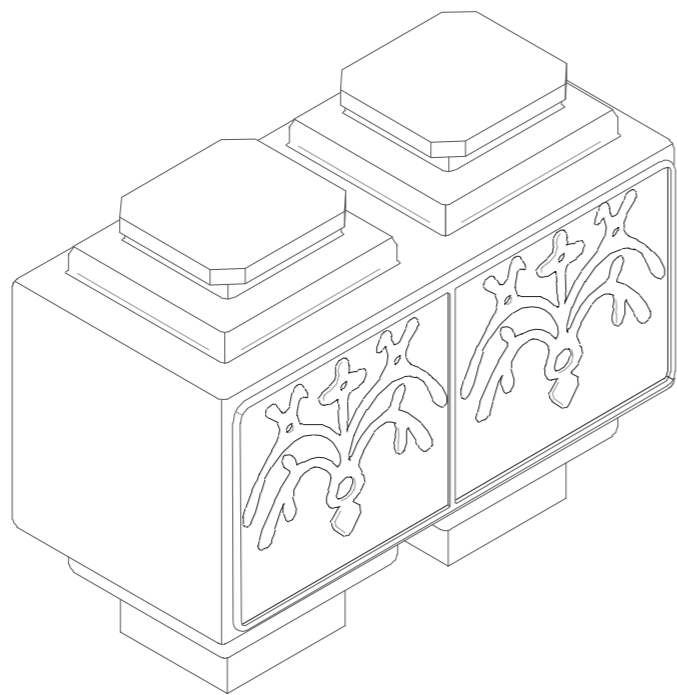

Isometric view

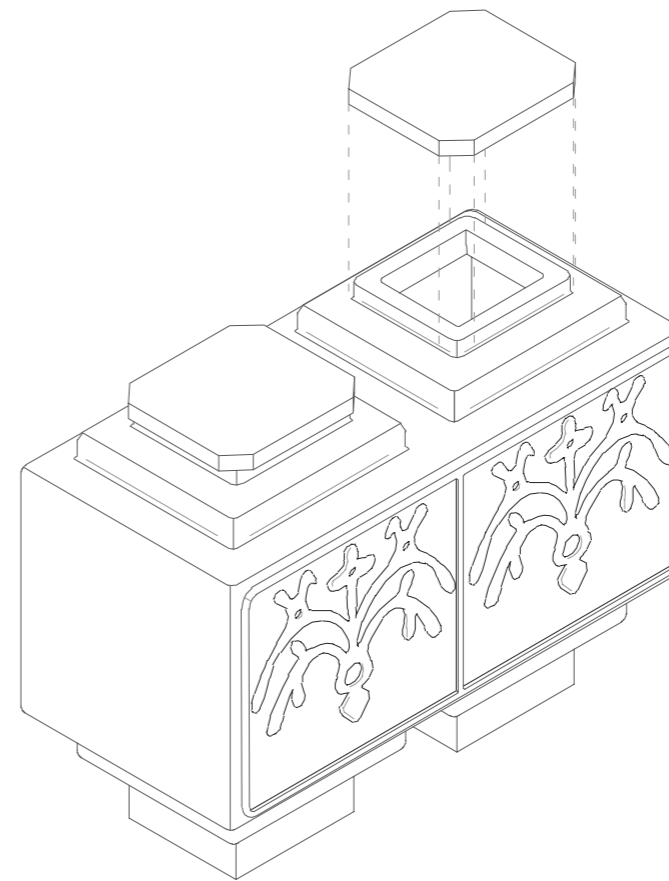

Isometric view (open)

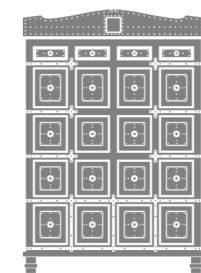

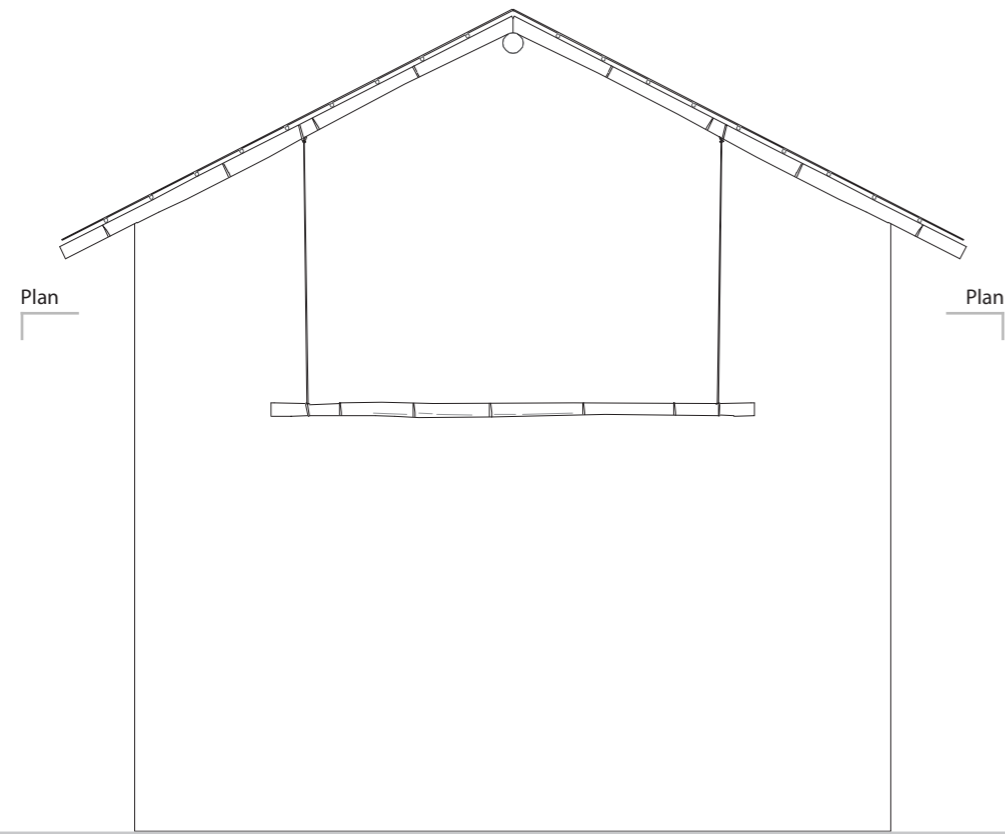

Front elevation

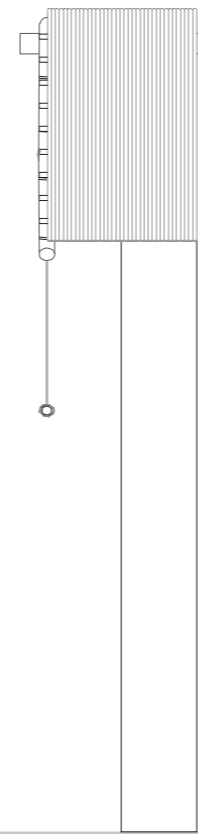

Side elevation

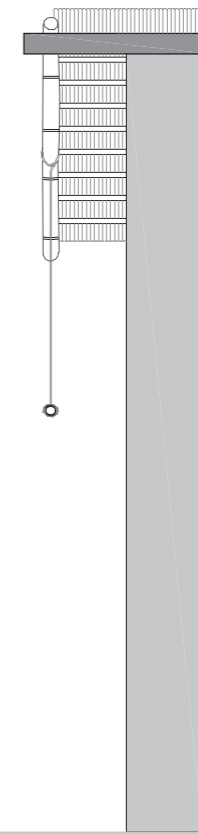

Section 1

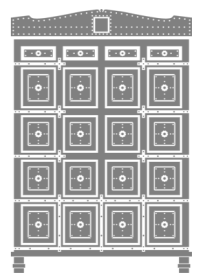
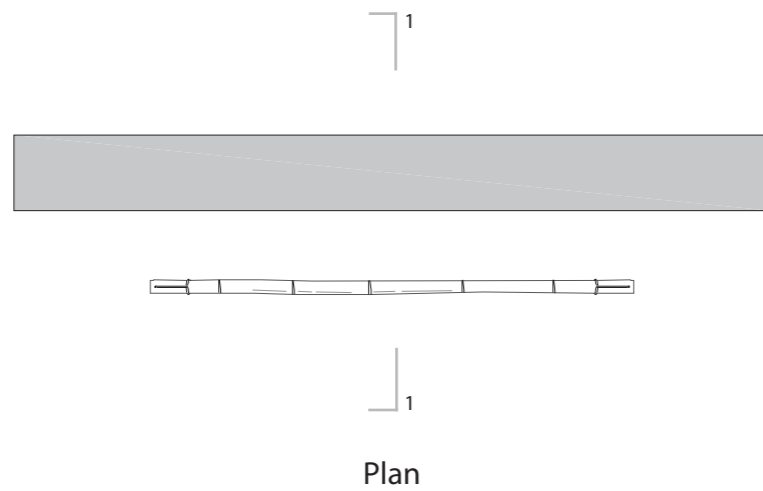

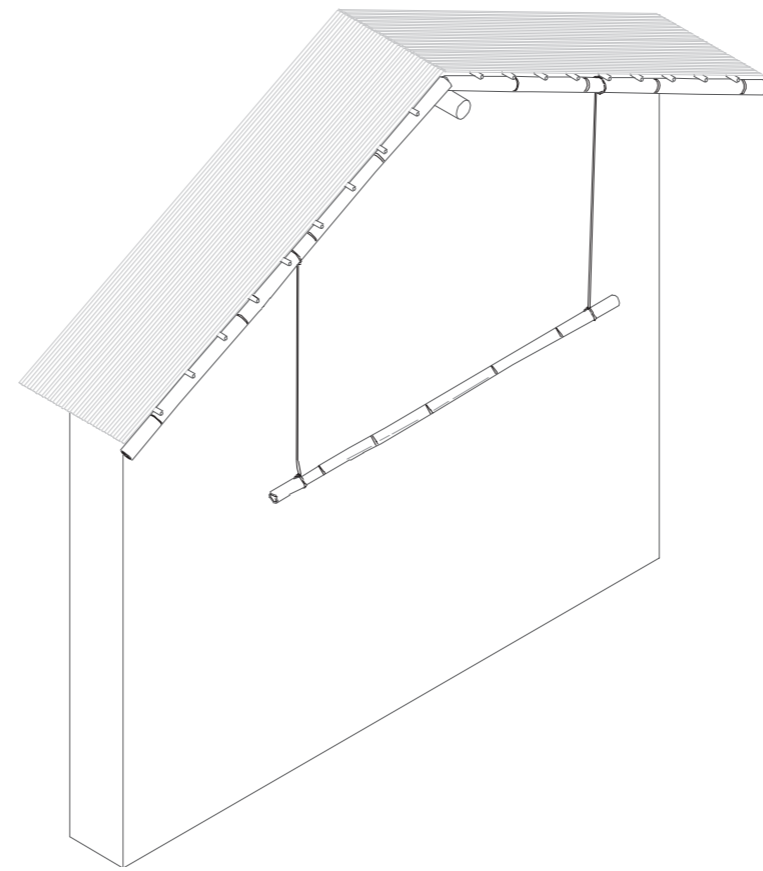

Isometric view

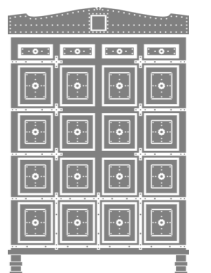

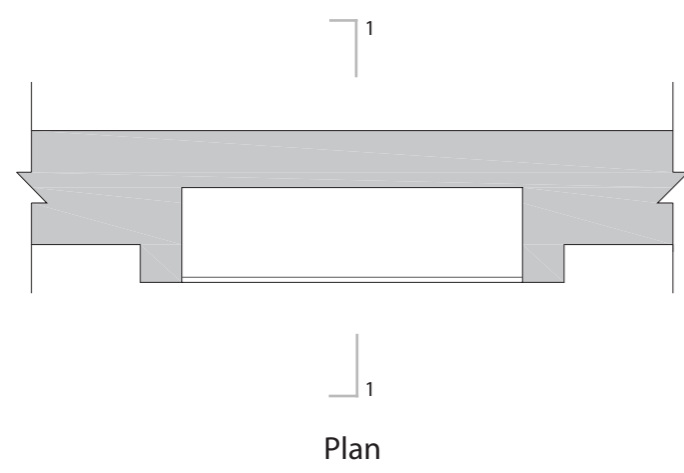
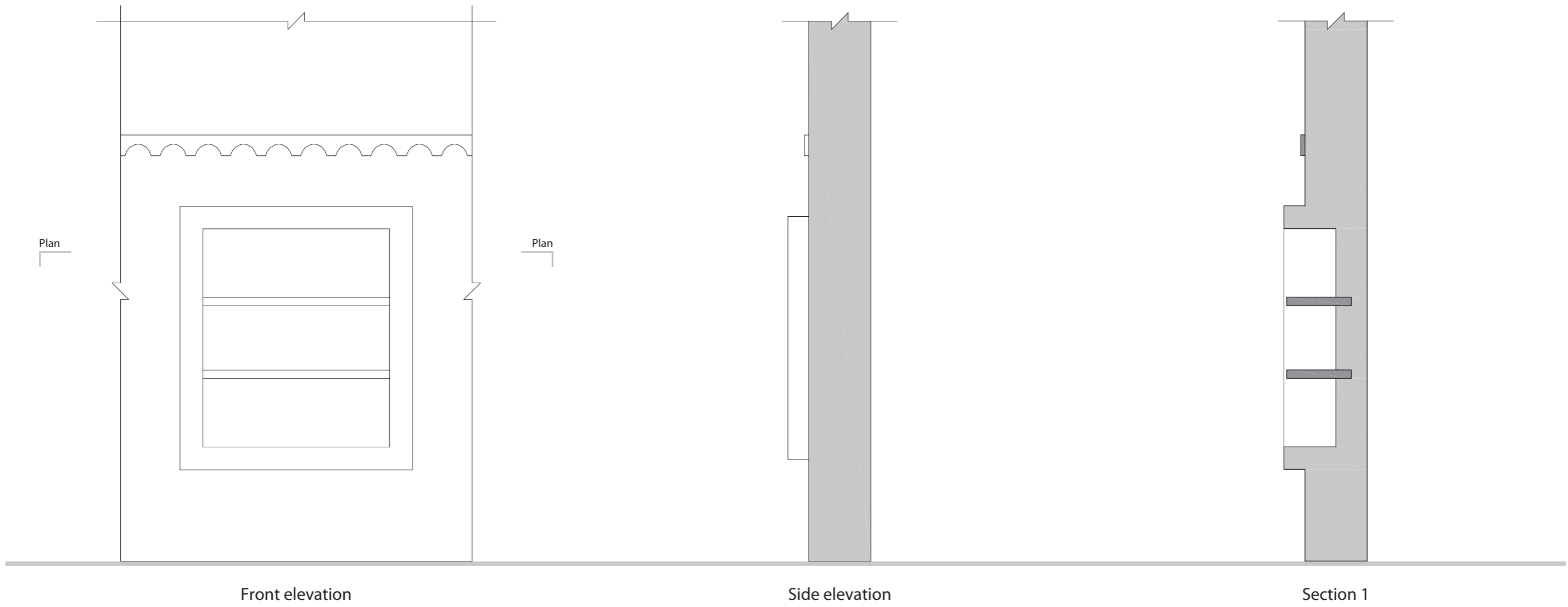

Vernacular Furniture of Punjab

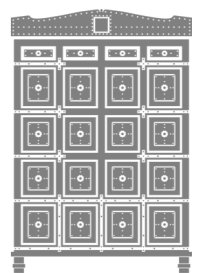

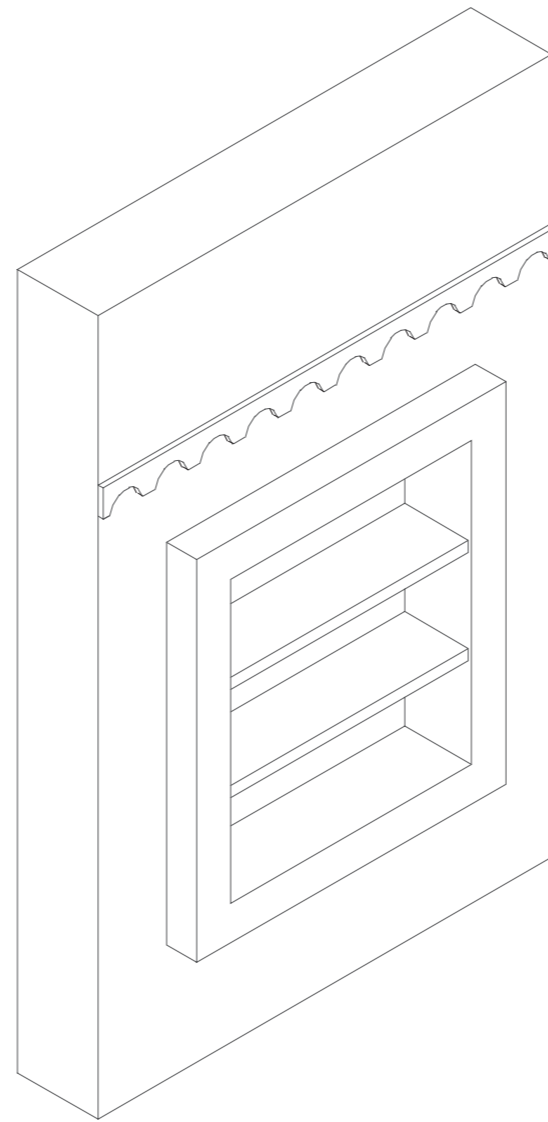

Isometric view

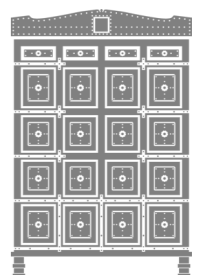

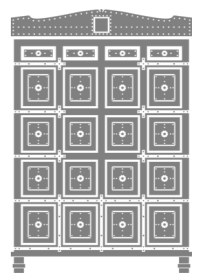
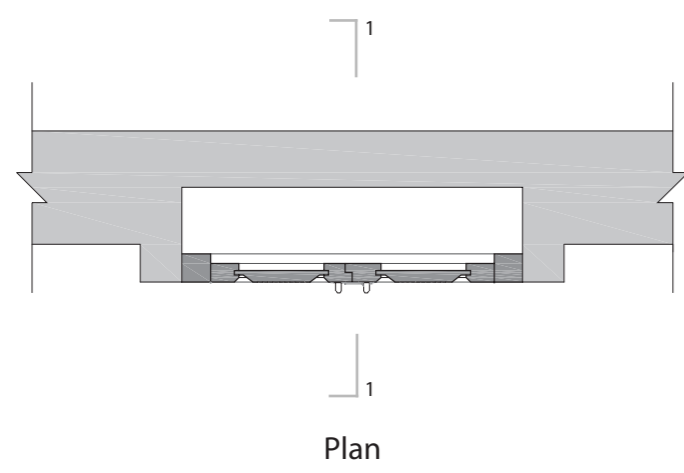
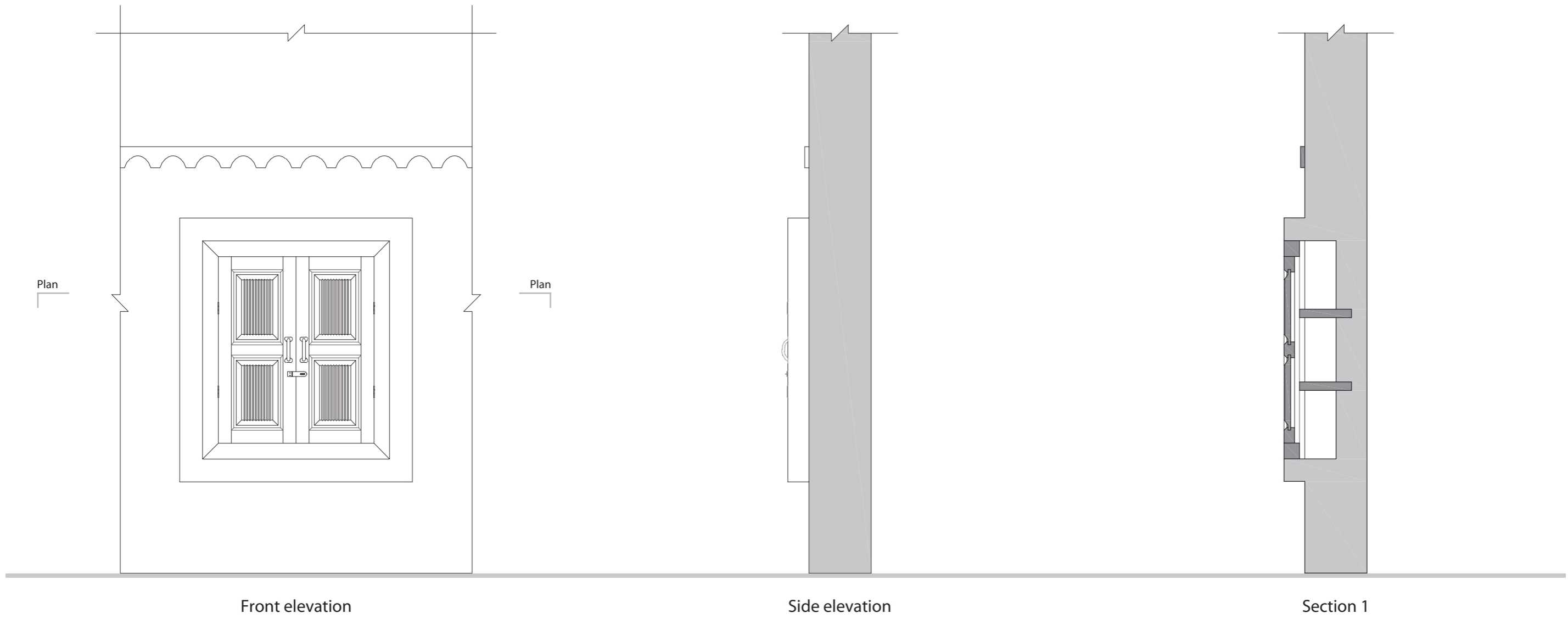

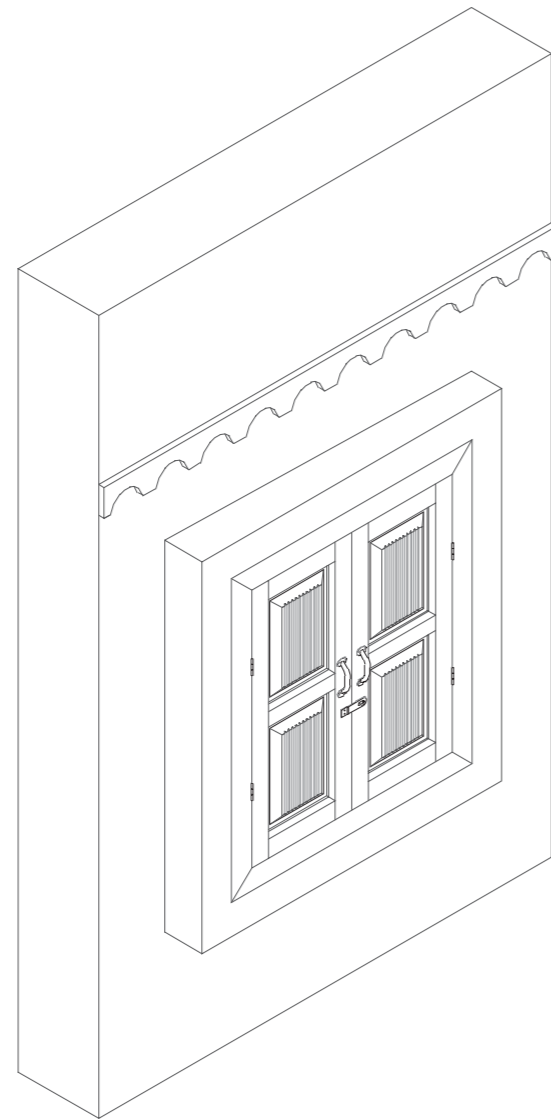

Isometric view

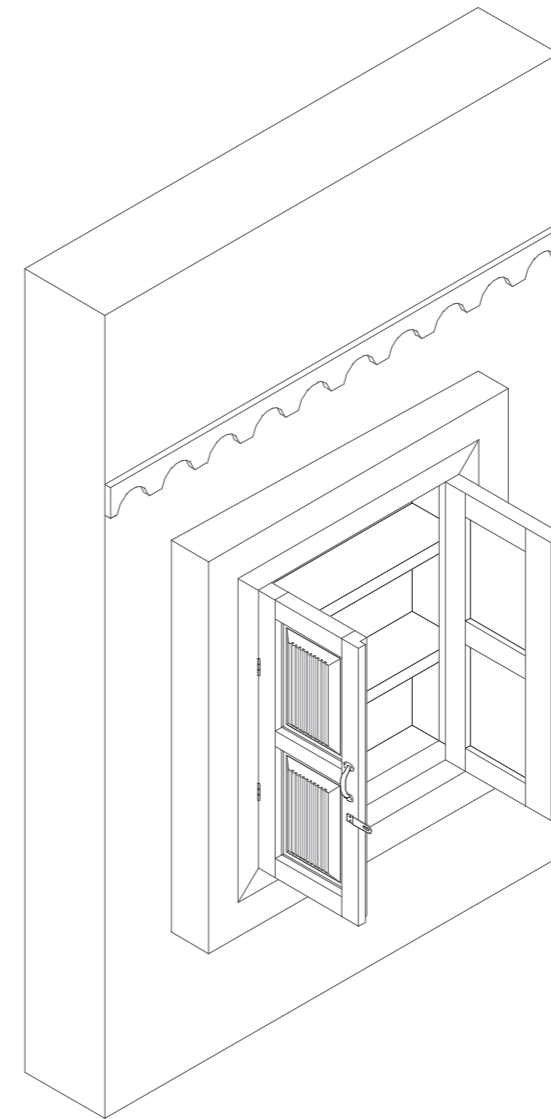

Isometric view (open)

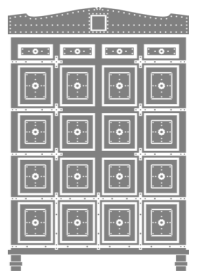

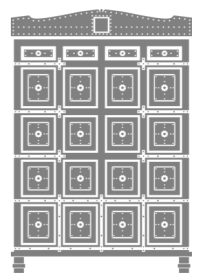
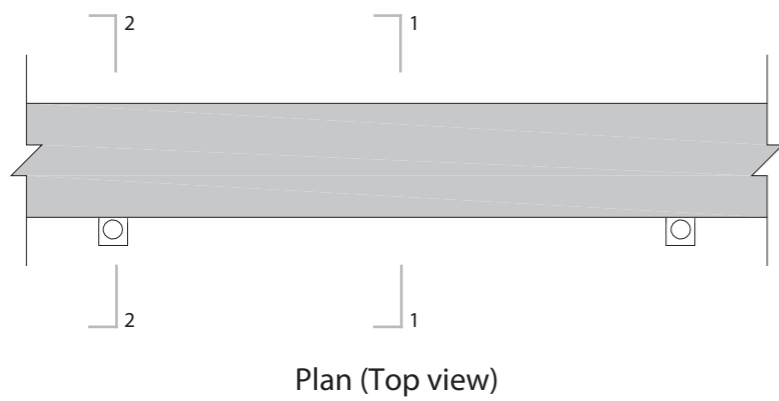
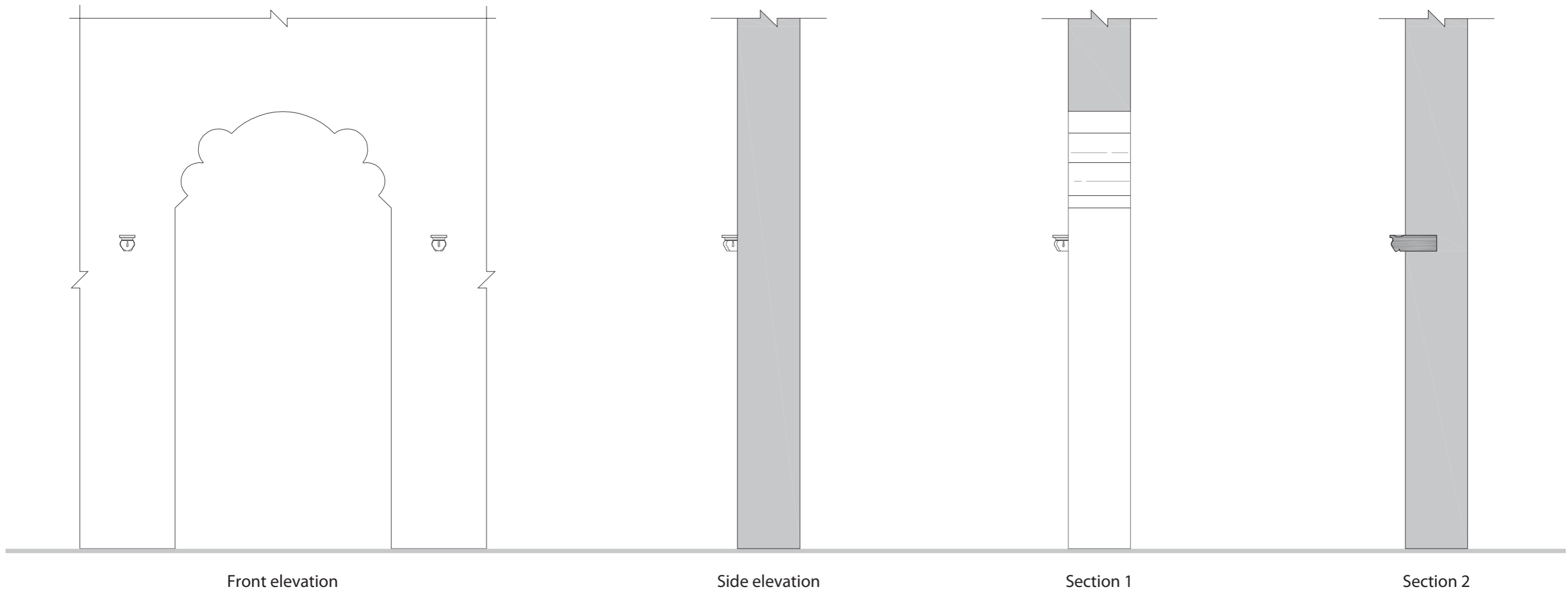

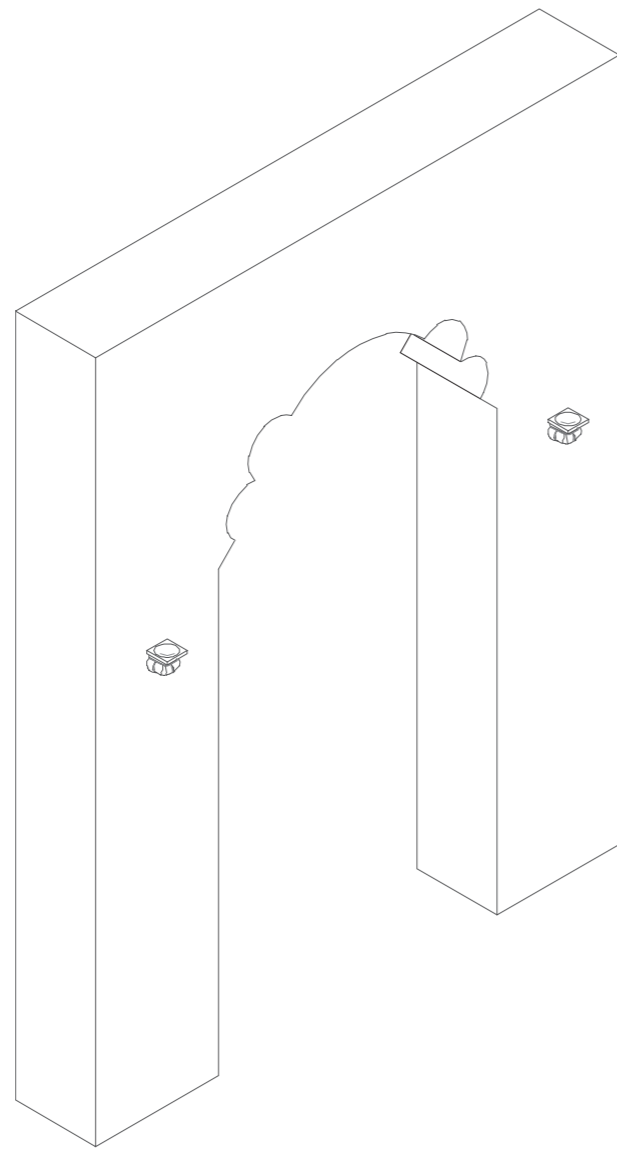

Isometric view

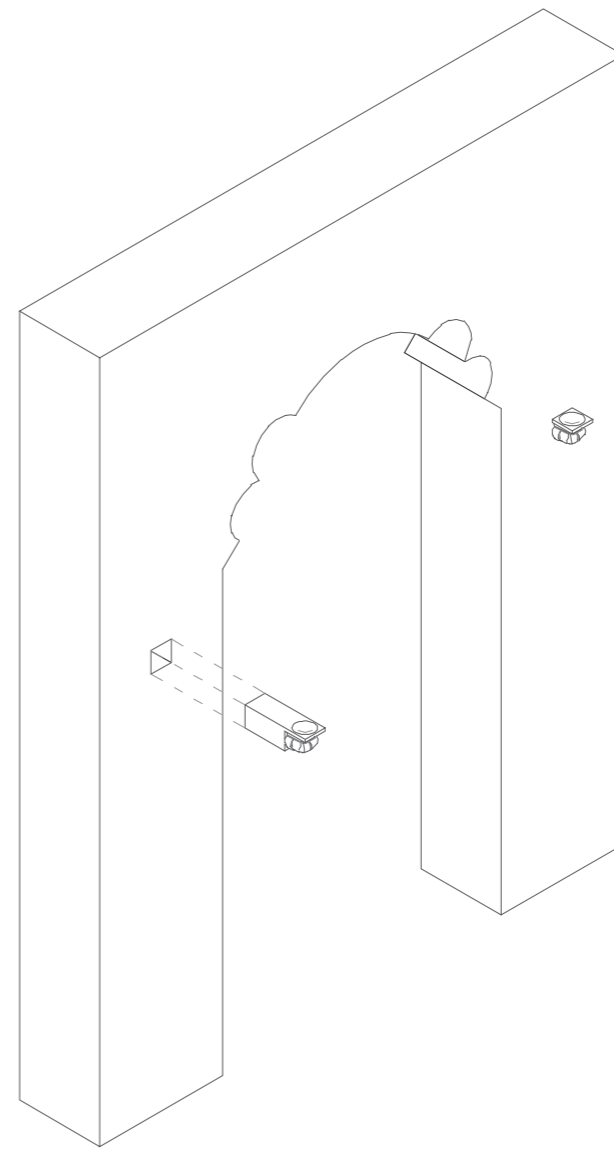

Exploded Isometric view

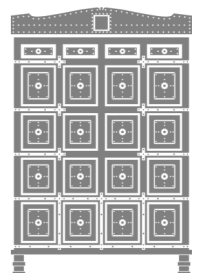

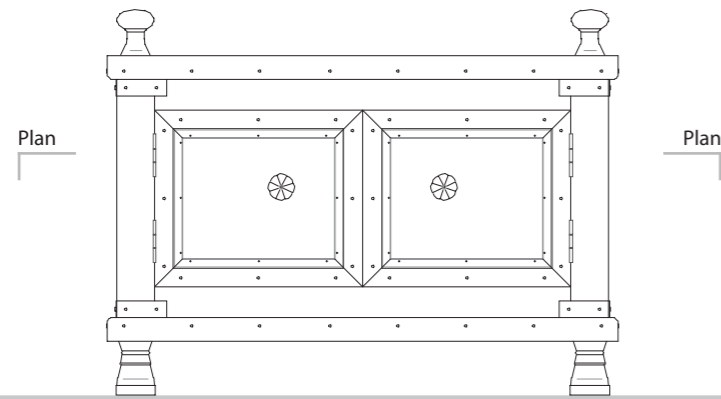

Front elevation

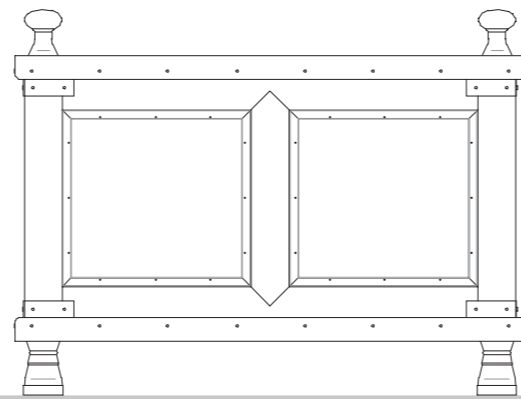

Side elevation

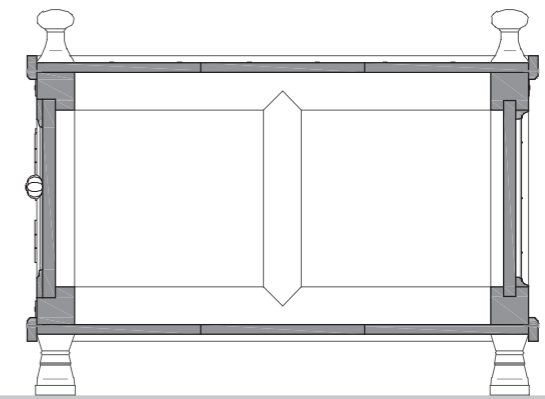

Section 1

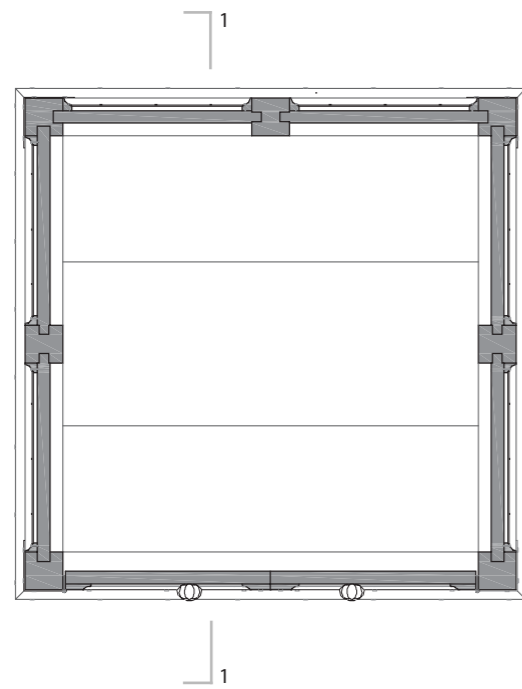

Plan

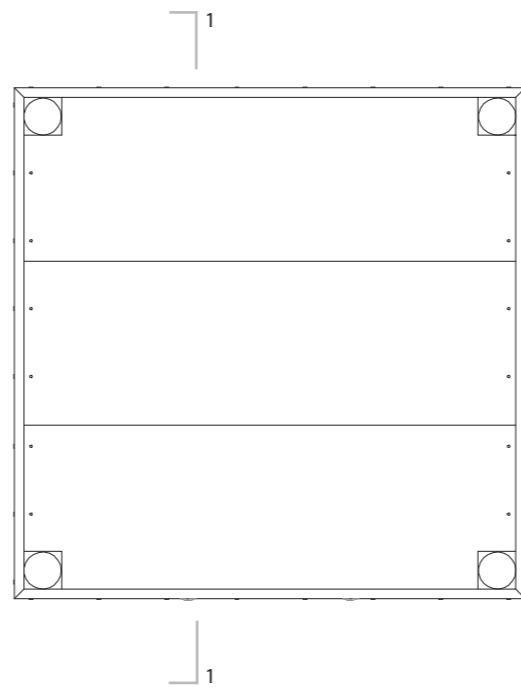

Plan (Top view)

Vernacular Furniture of Punjab

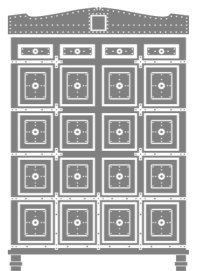

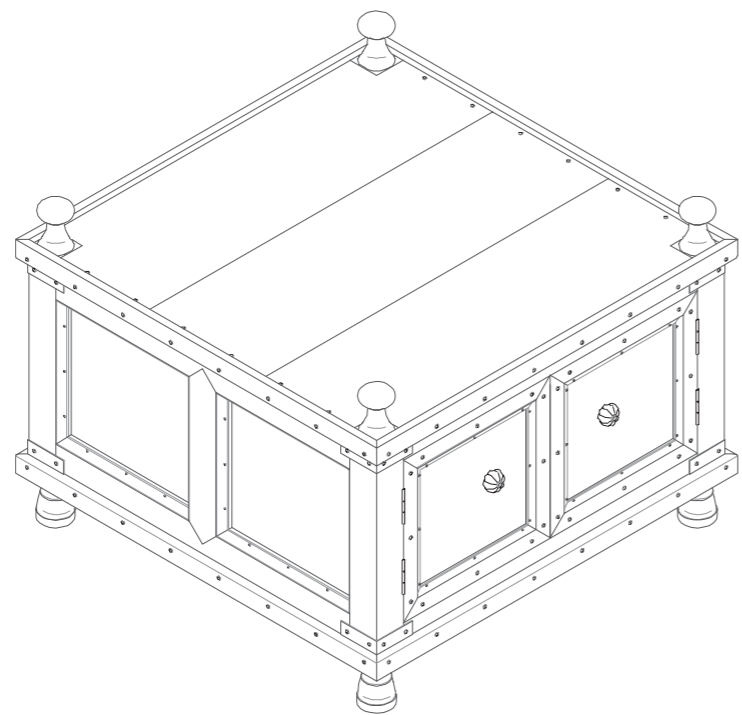

Isometric view

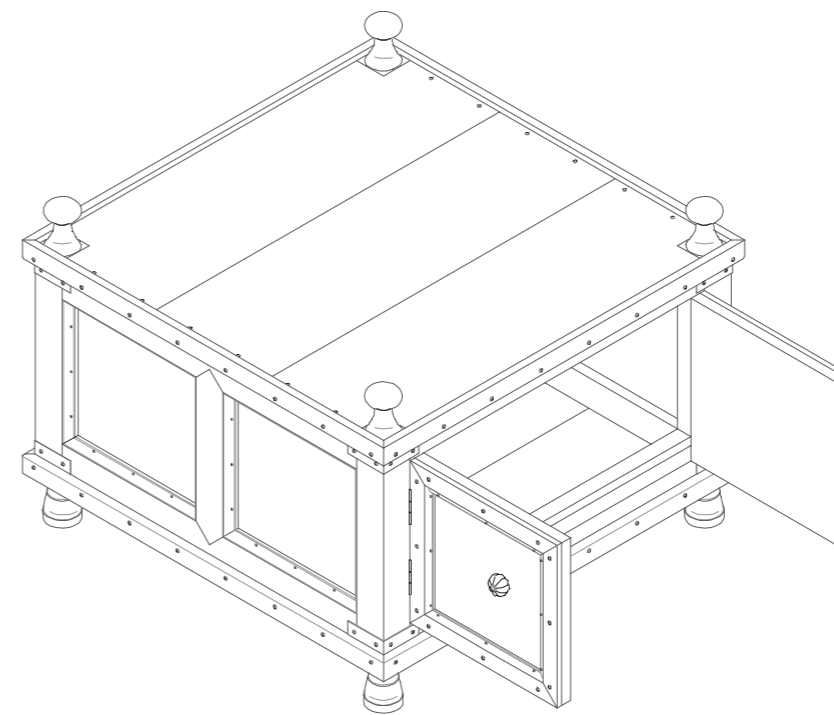

Isometric view (open)

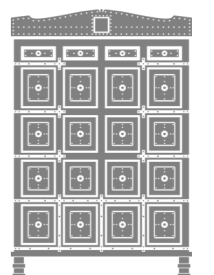

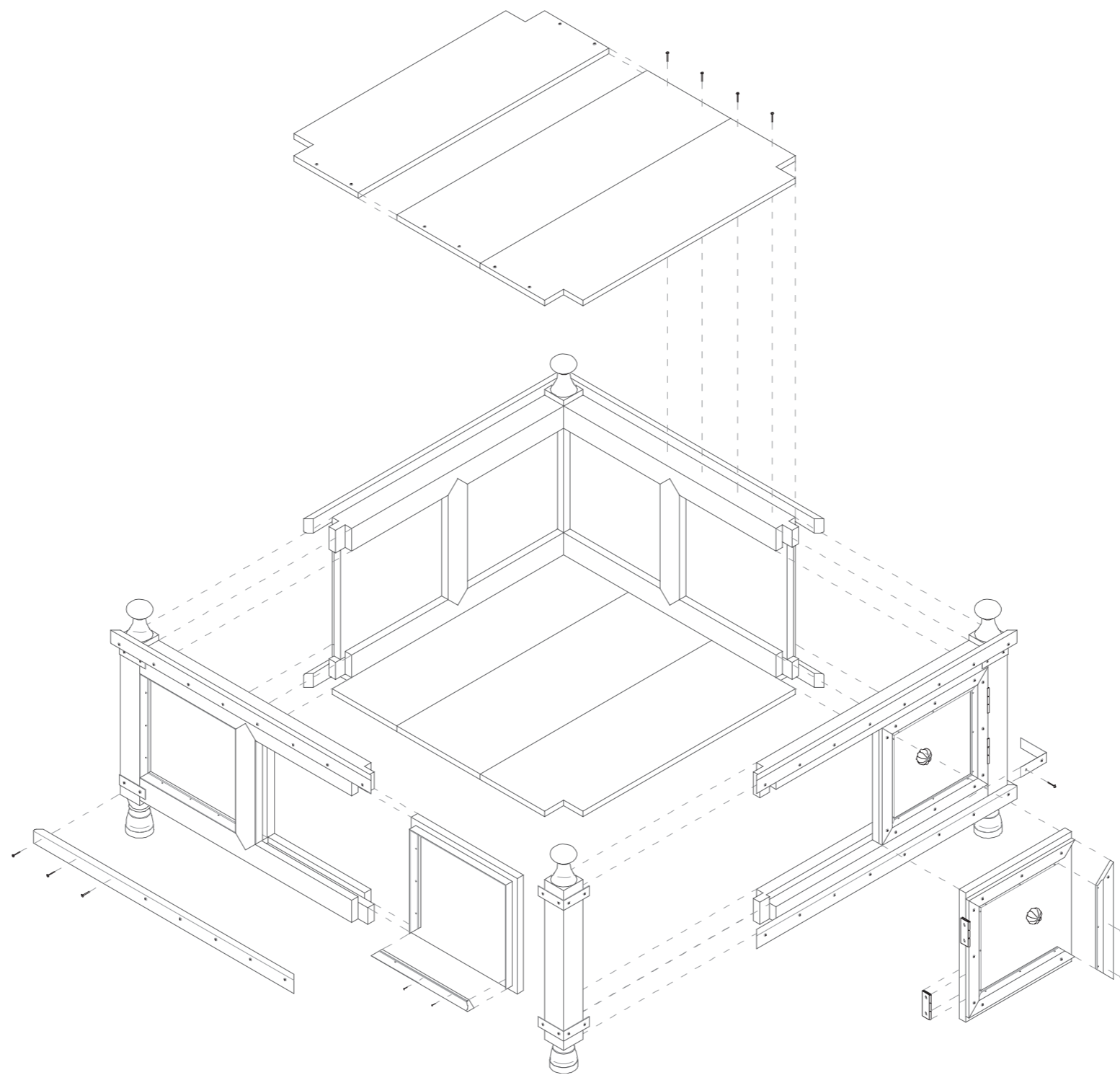

Exploded Isometric view



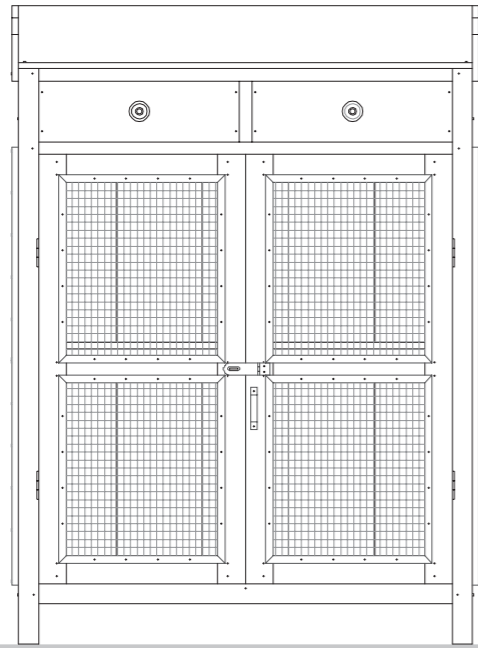

Front elevation

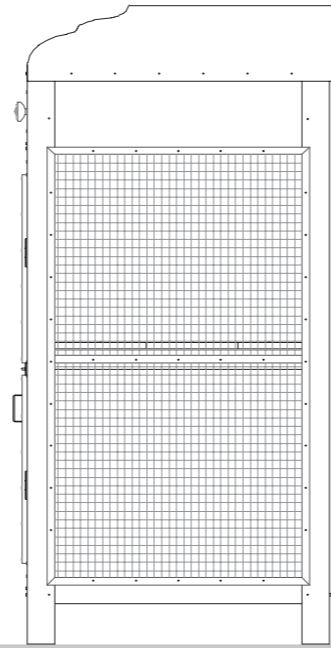

Side elevation

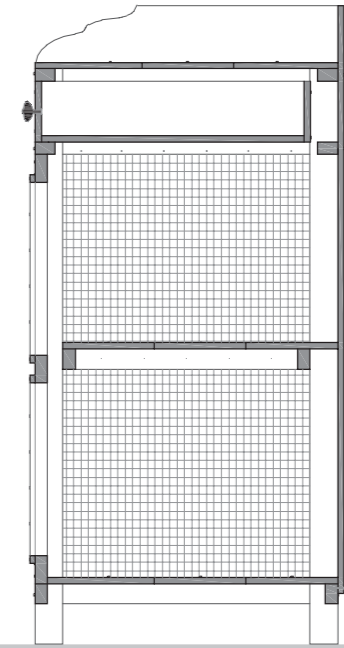

Section 1

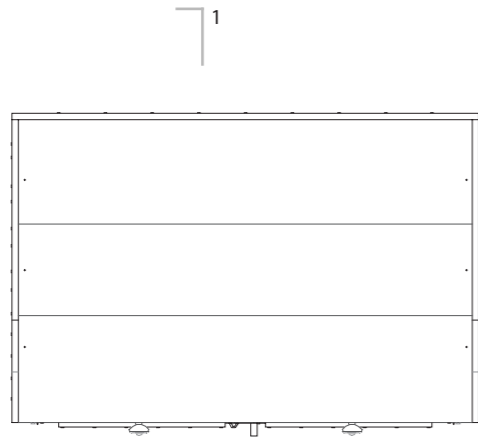

Plan (Top view)

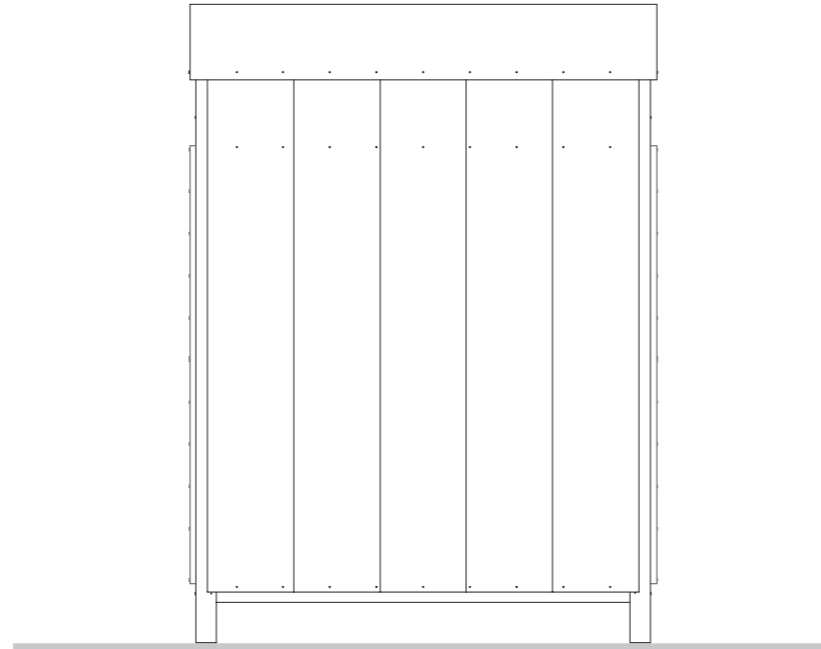

Back elevation

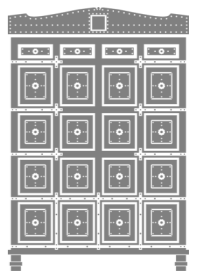

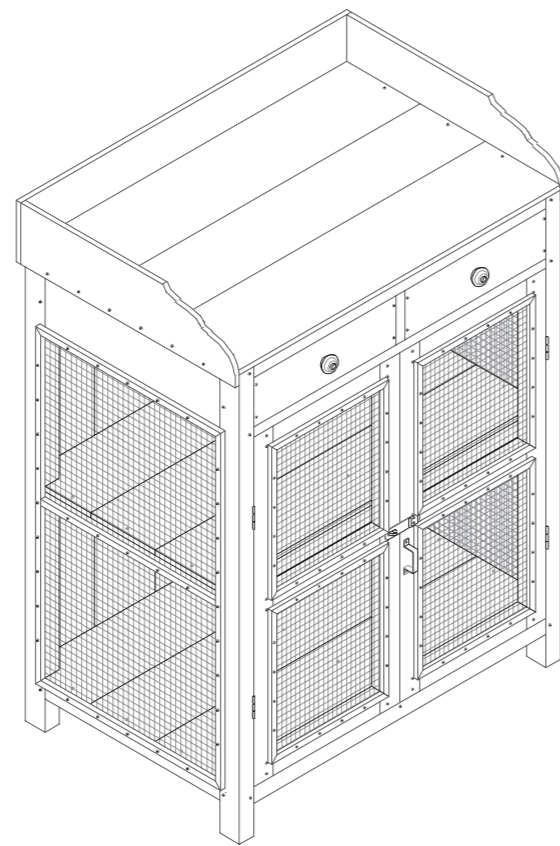

Isometric view

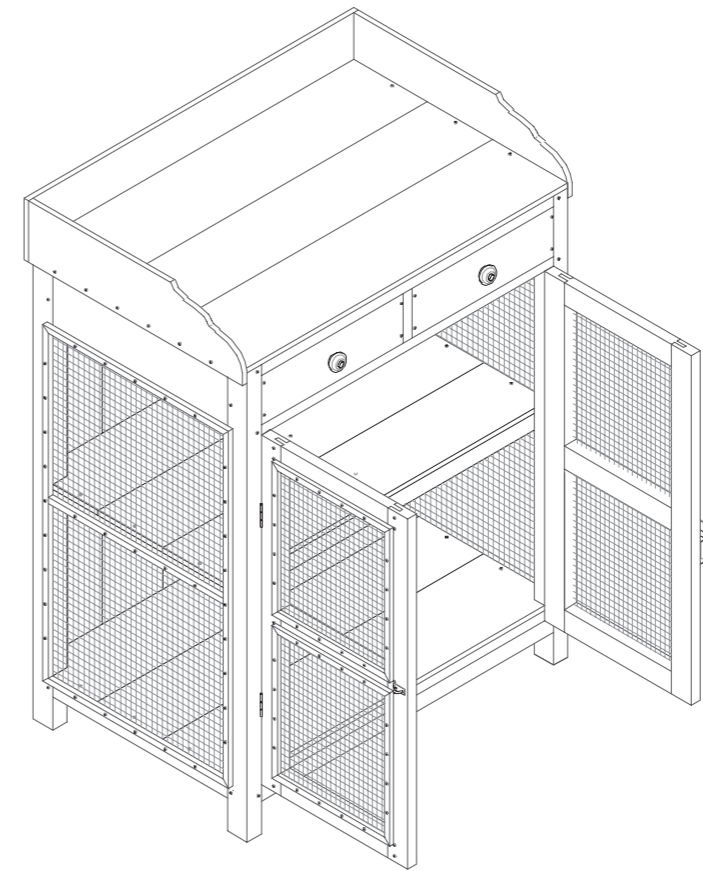

Isometric view (open)

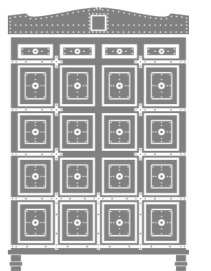

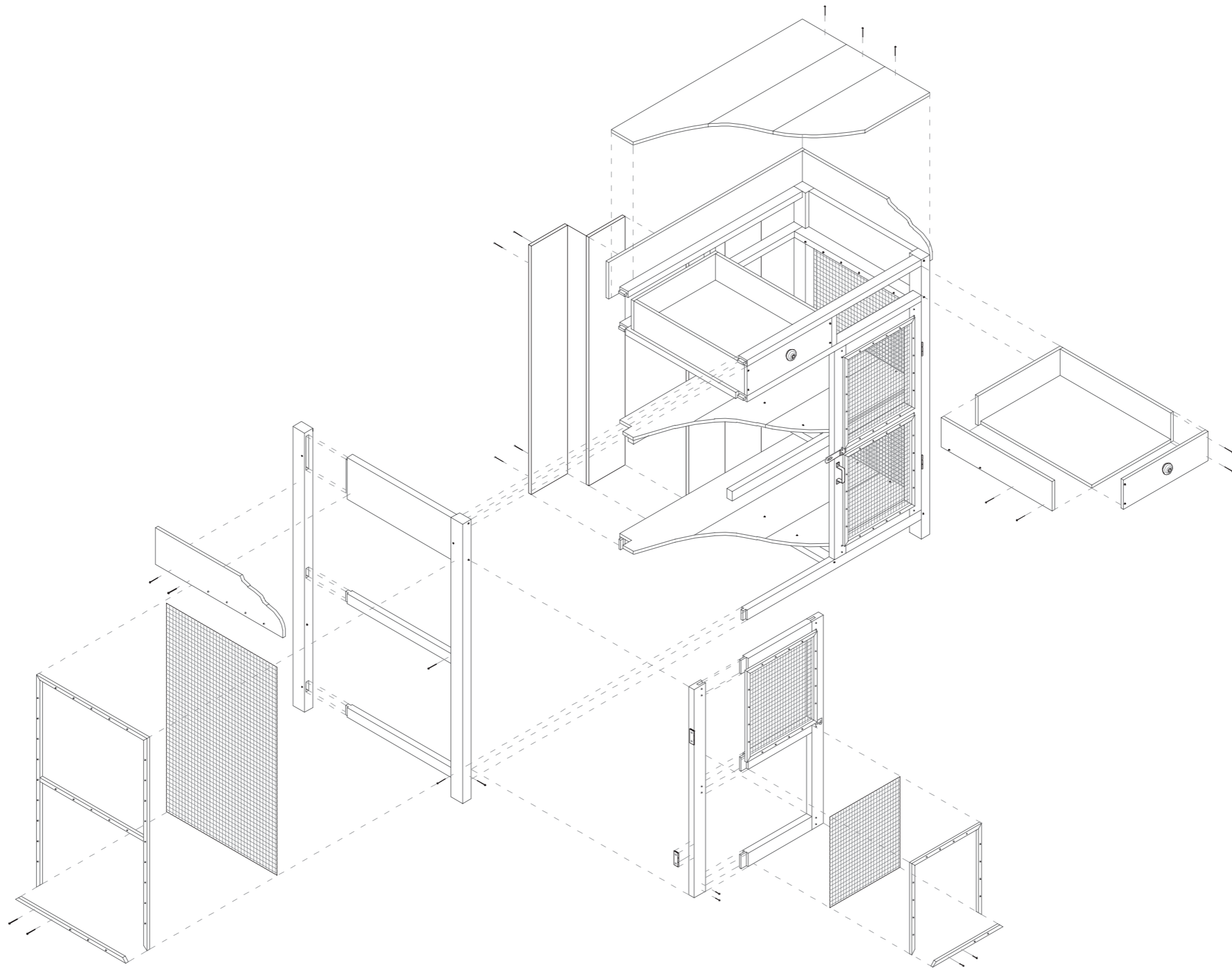

Isometric view (open)

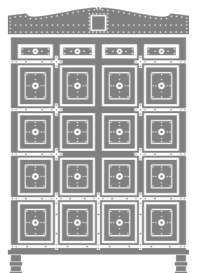

Plan

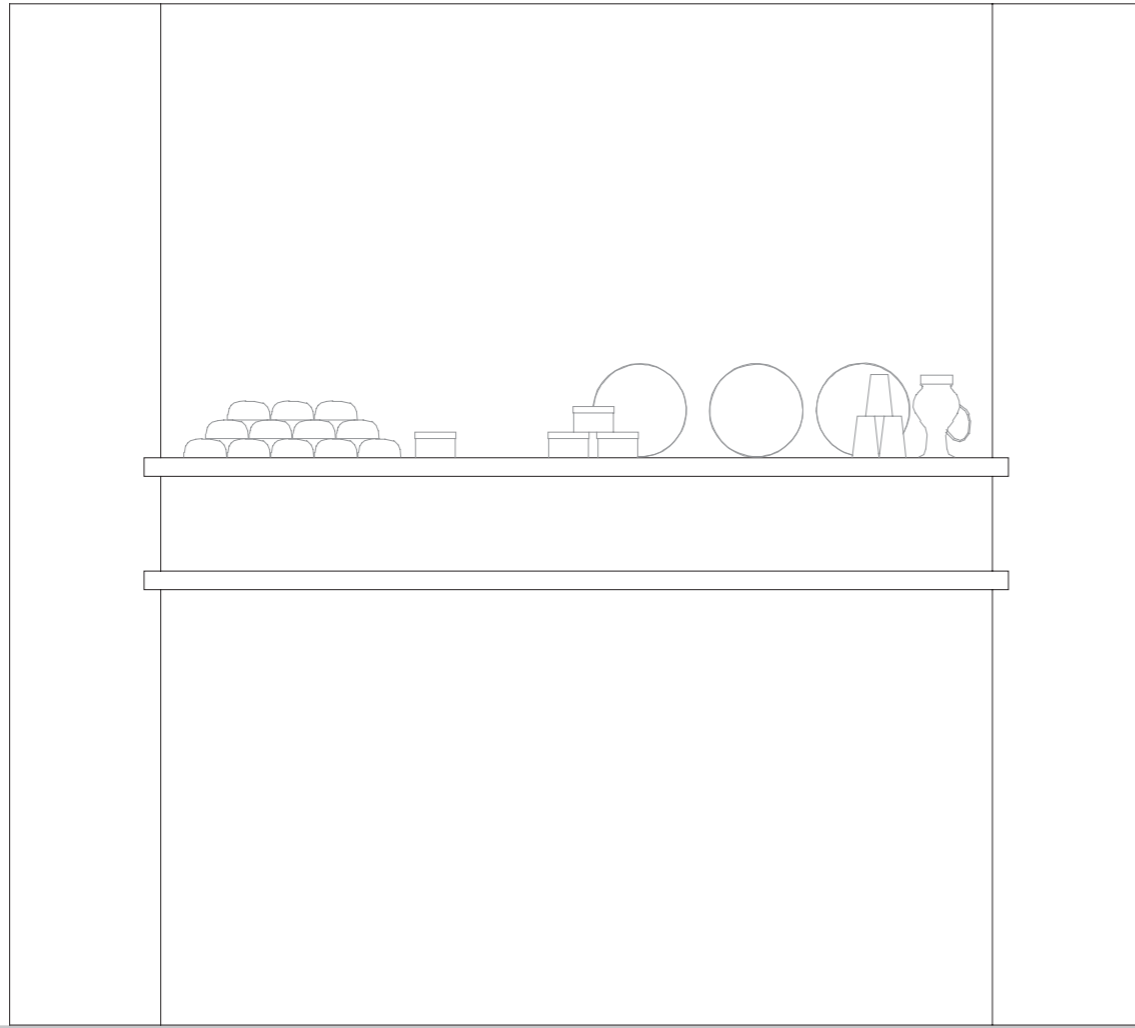

Front elevation

Plan

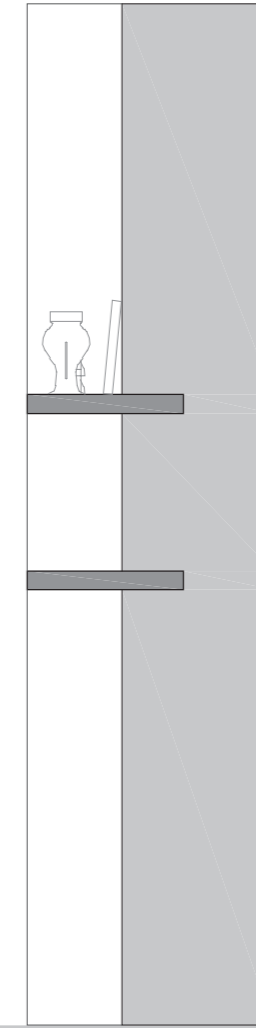

Section 1

1

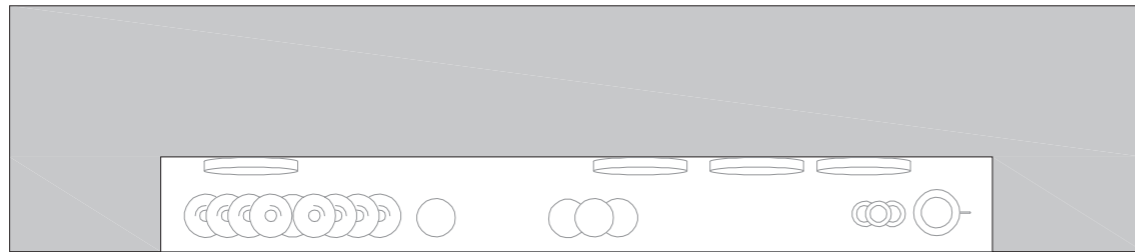

1

Plan

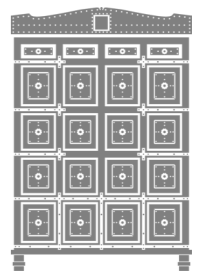

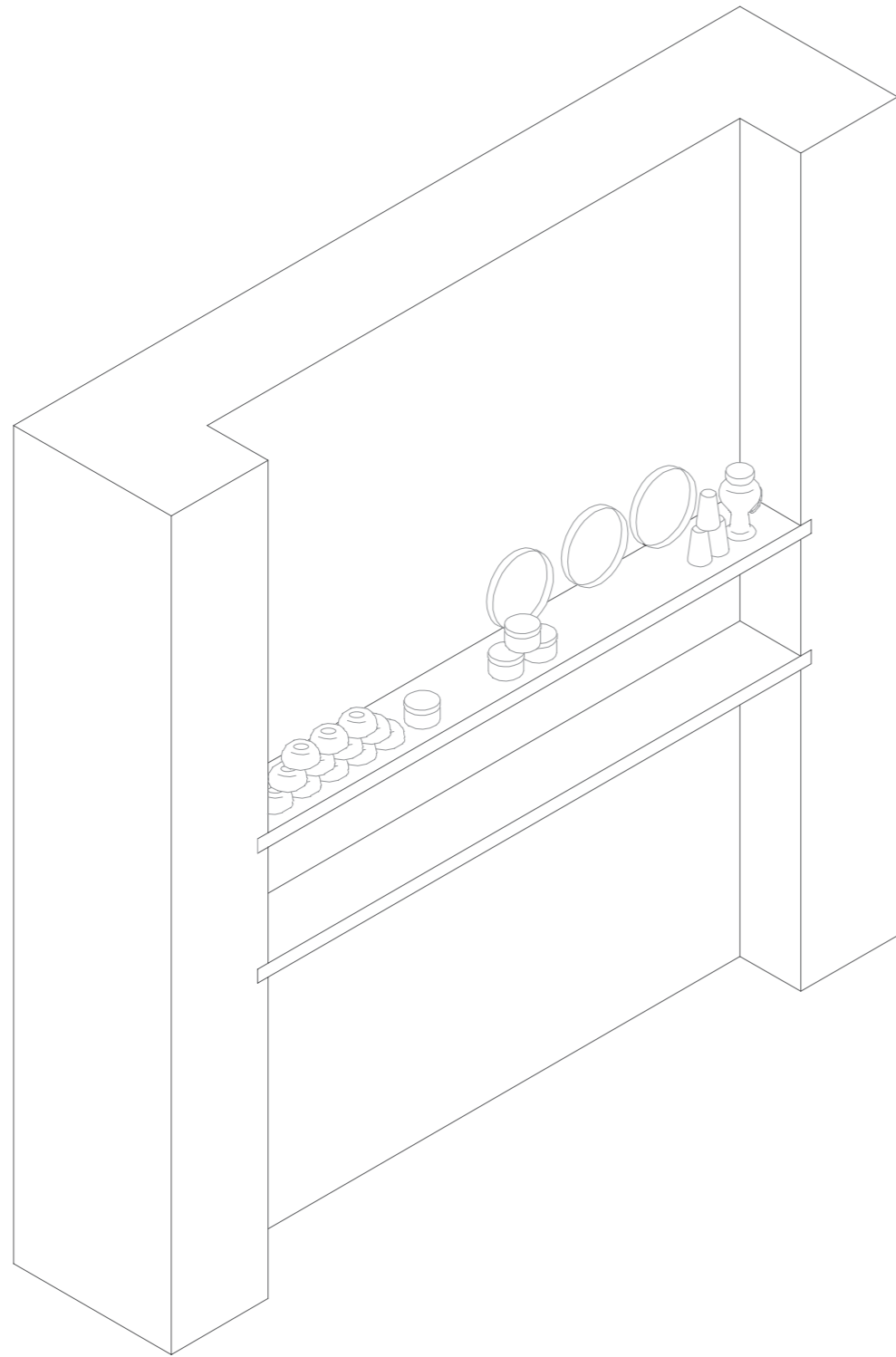

Isometric view

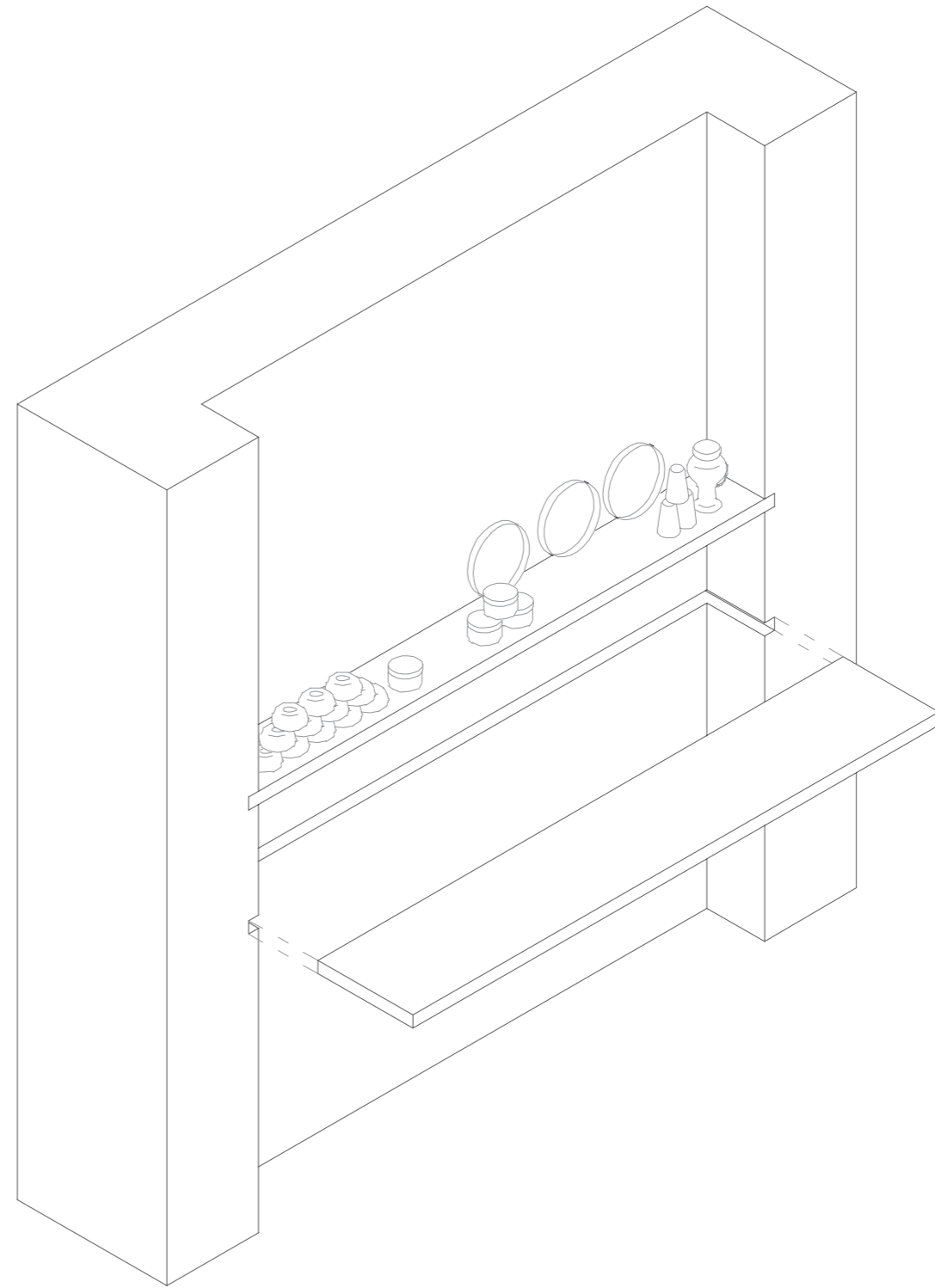

Exploded Isometric view

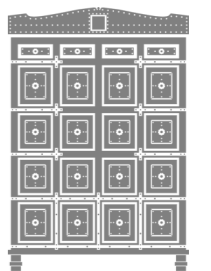

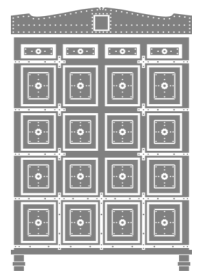
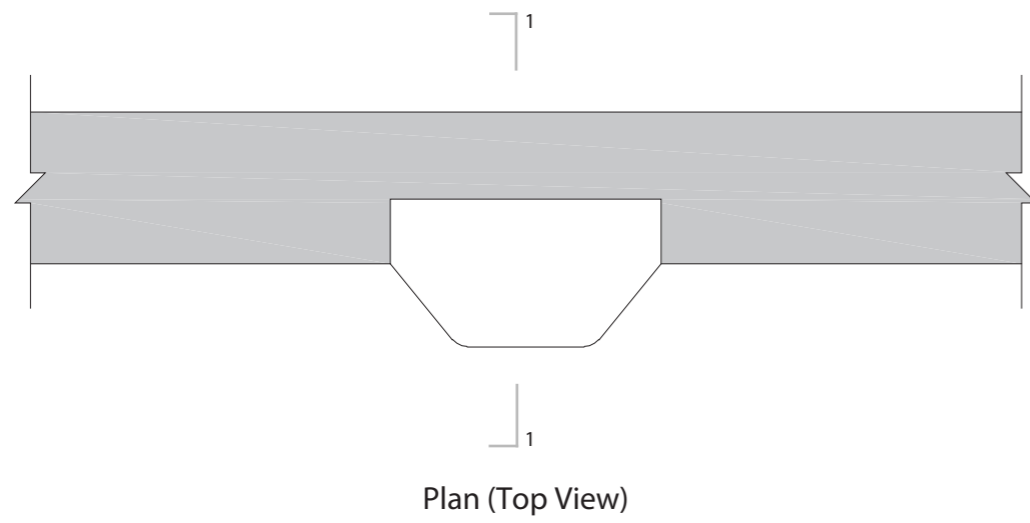
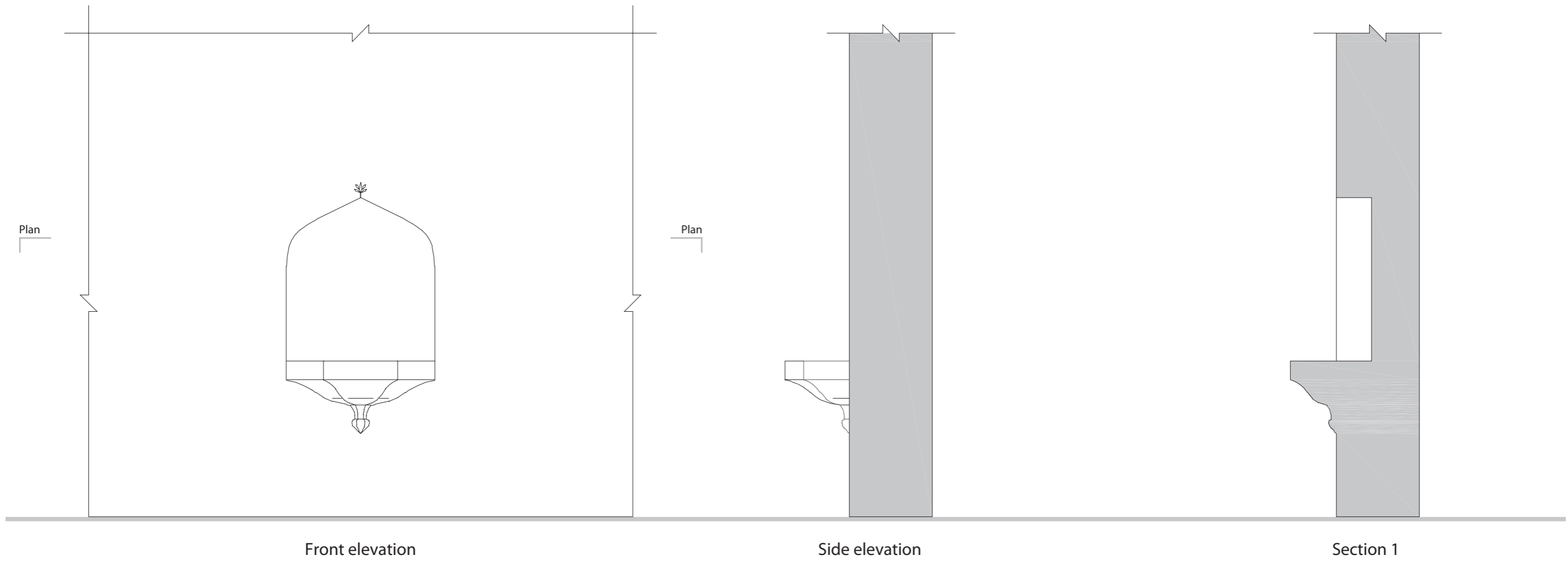

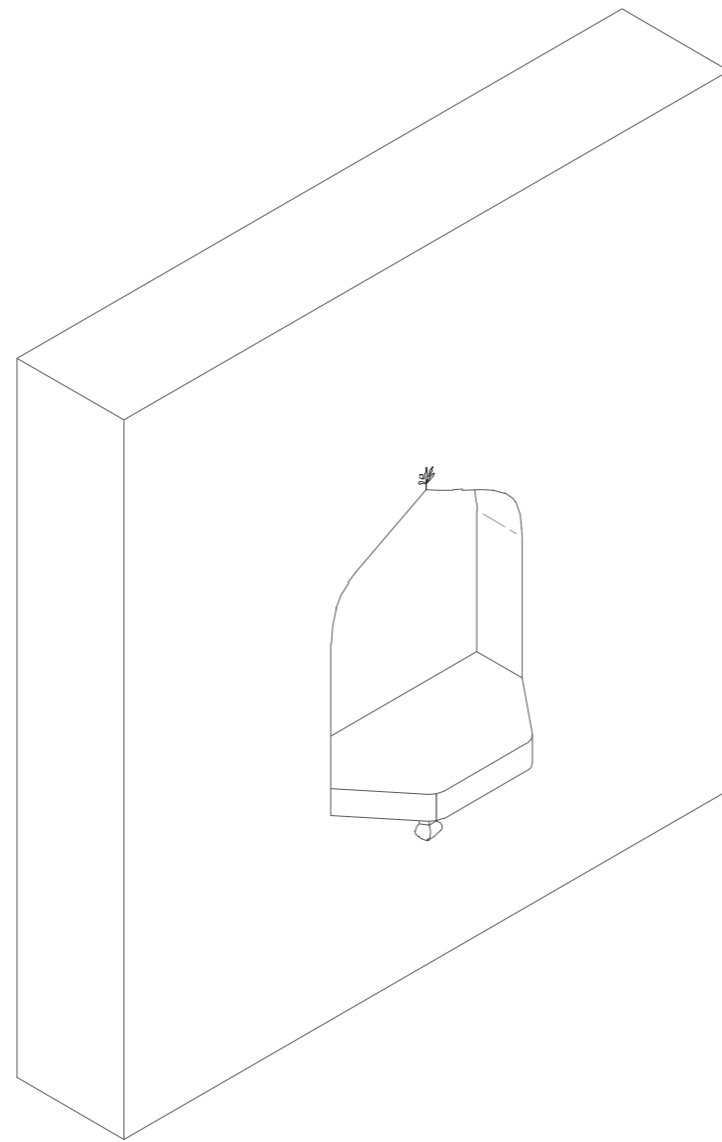

Isometric view

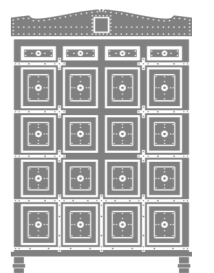

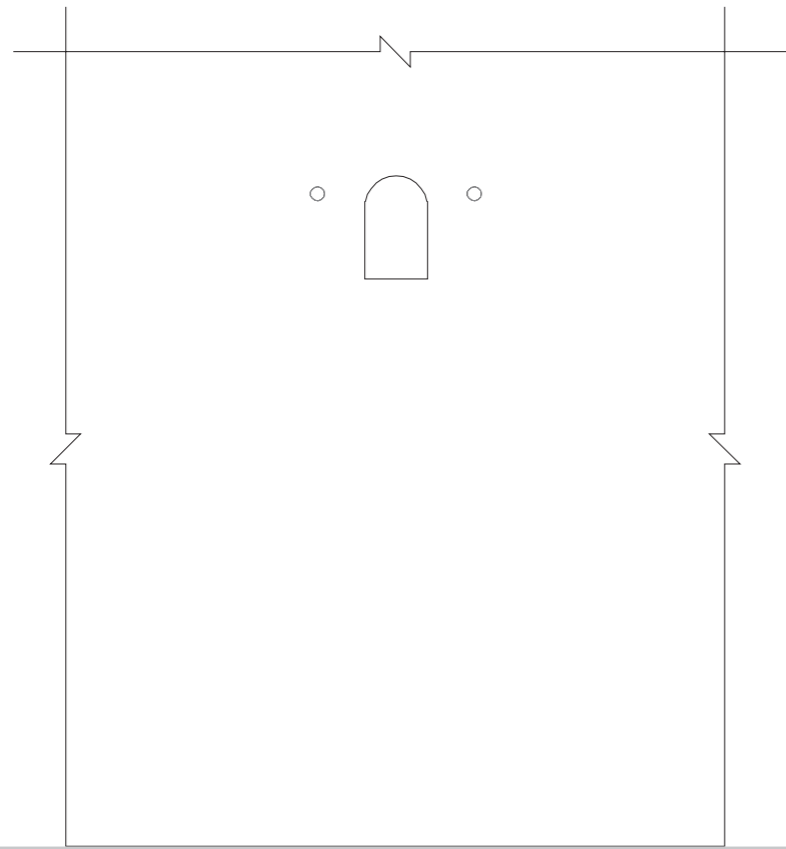

Front elevation

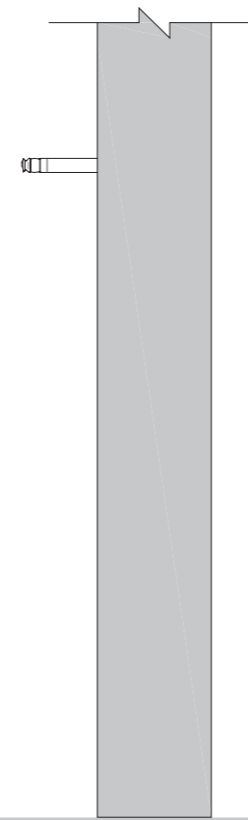

Side elevation

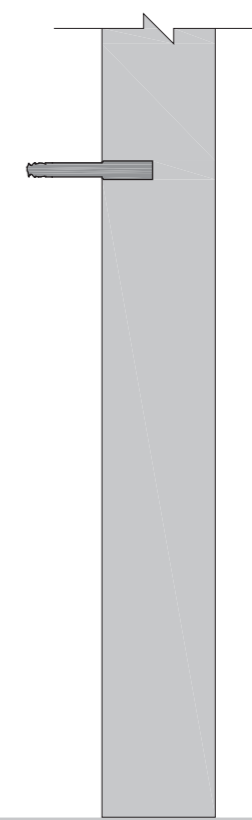

Section 1

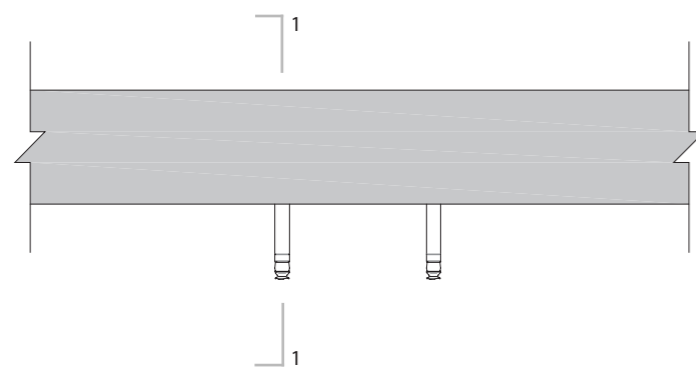

Plan (Top view)

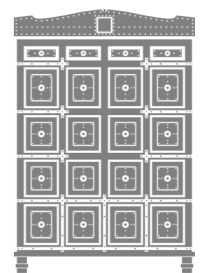

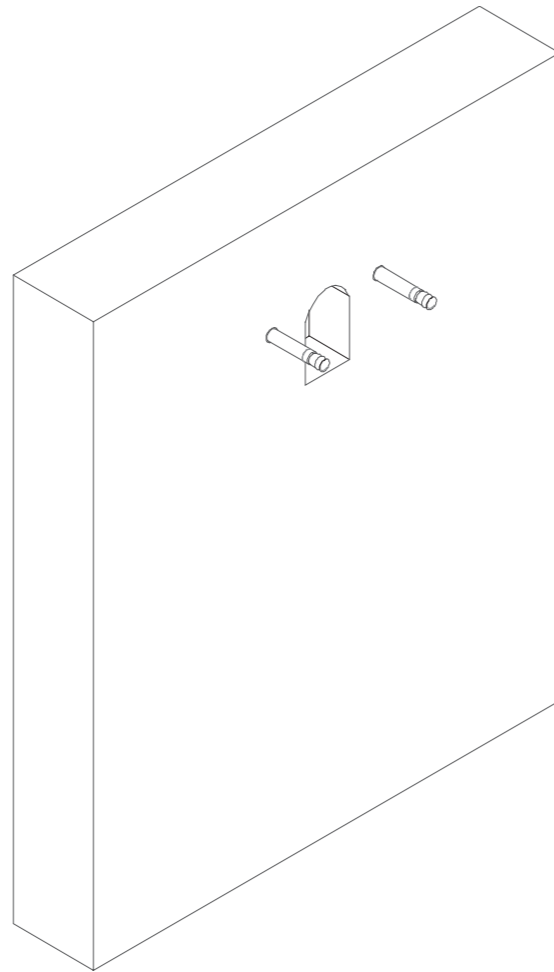

Isometric view

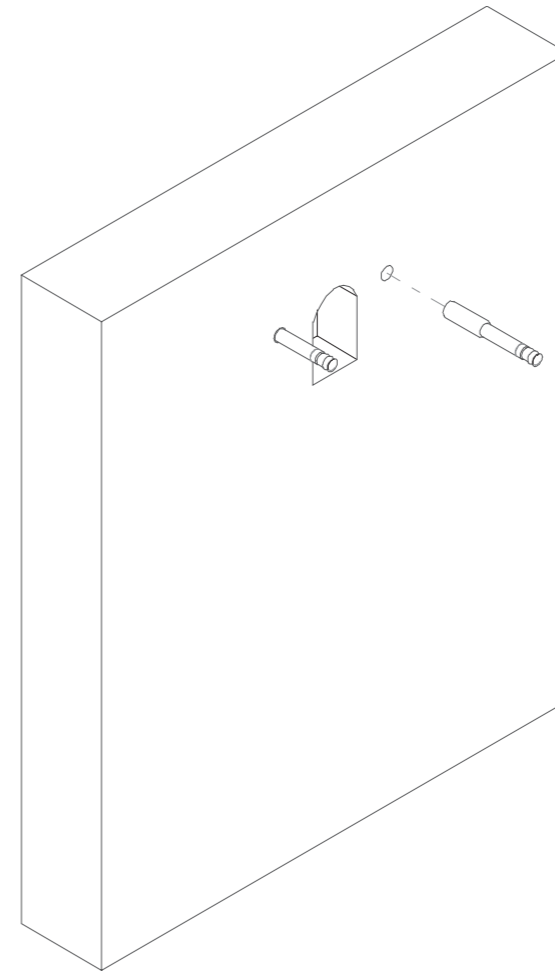

Exploded Isometric view

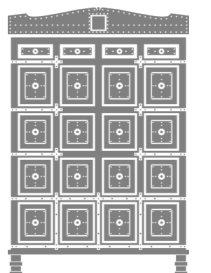

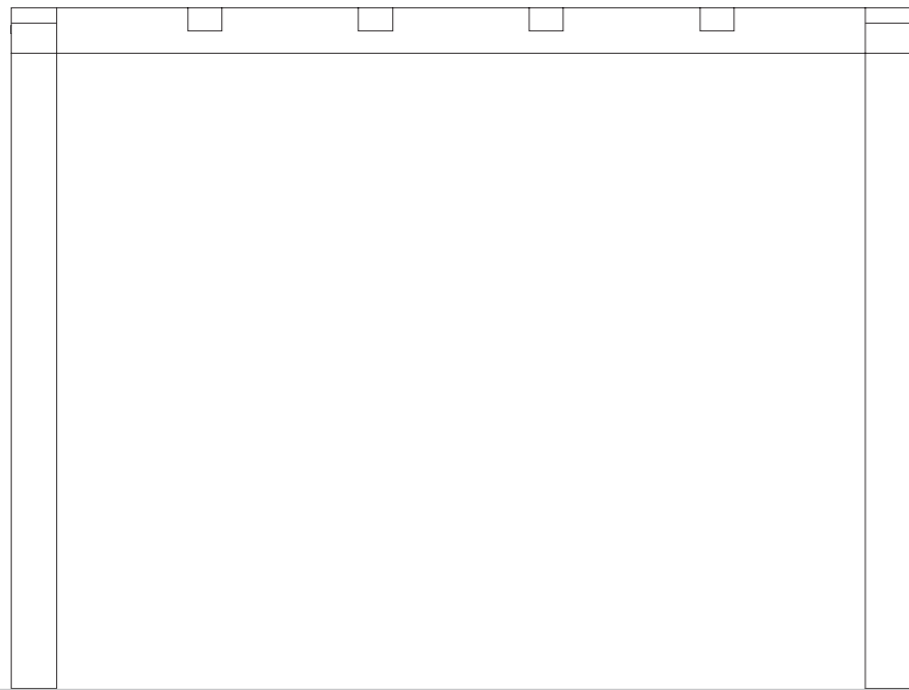

Front elevation

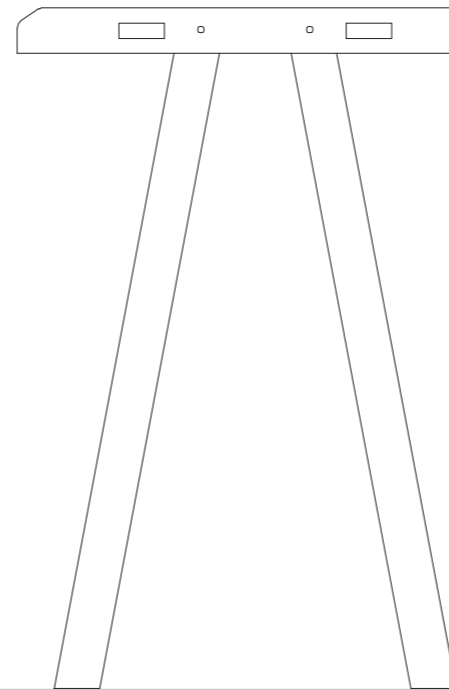

Side elevation

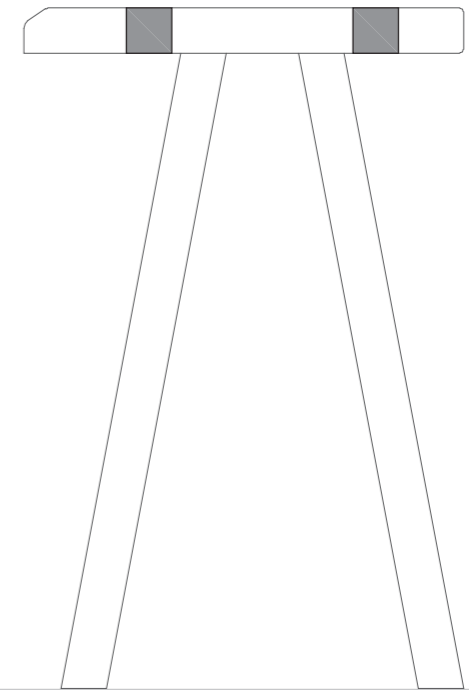

Section 1

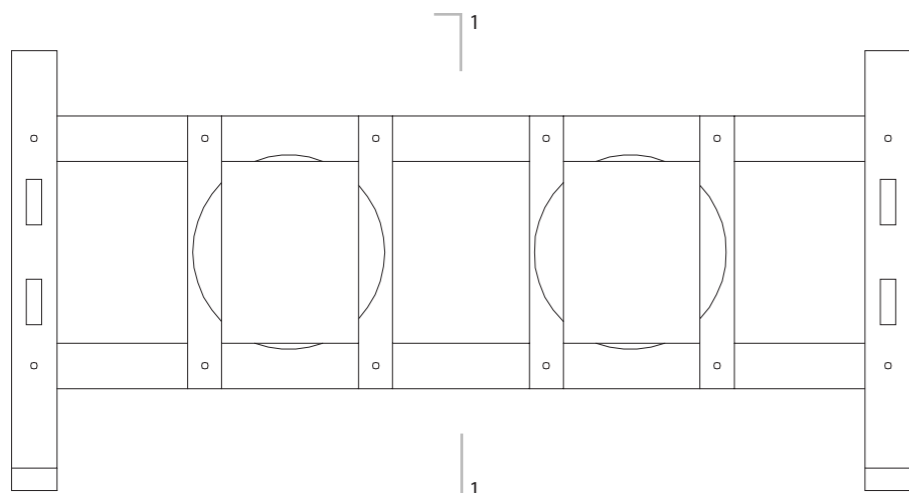

Plan

Vernacular Furniture of Punjab

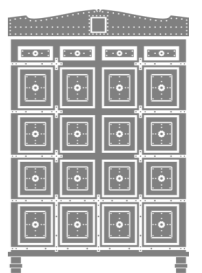

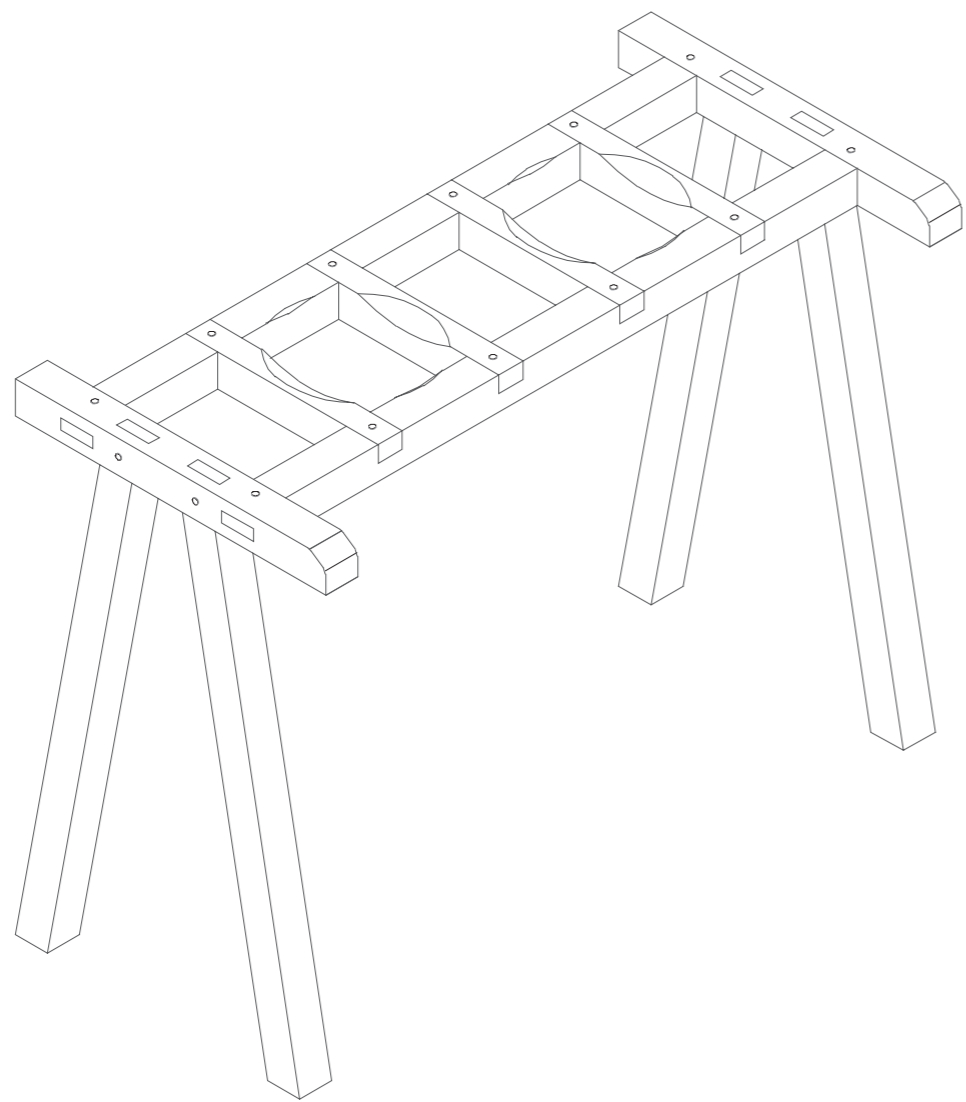

Isometric view

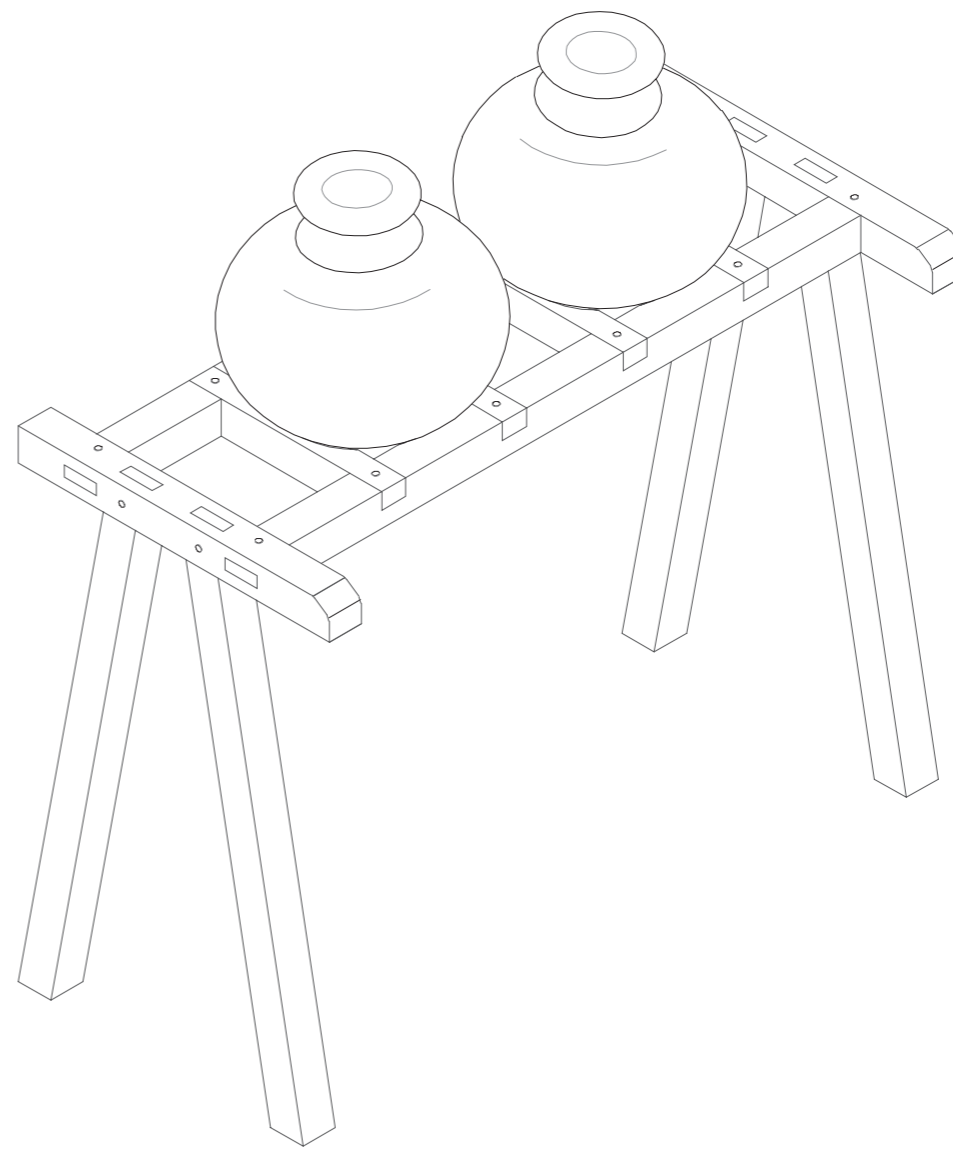

Isometric view

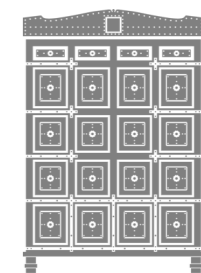

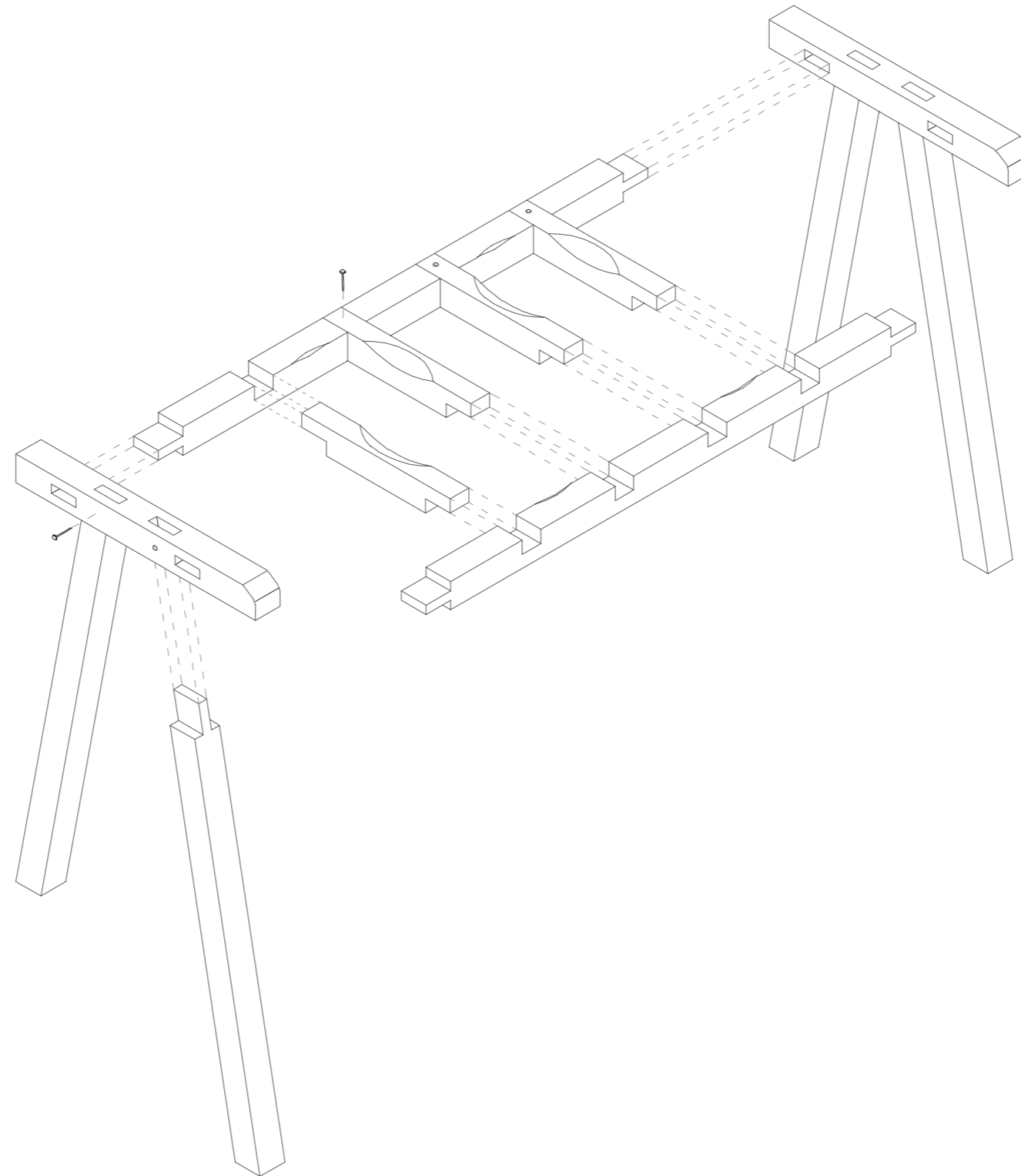

Exploded Isometric view

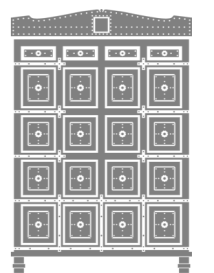



sapaat
surface

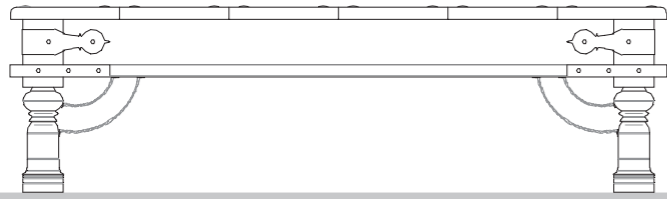

Front elevation

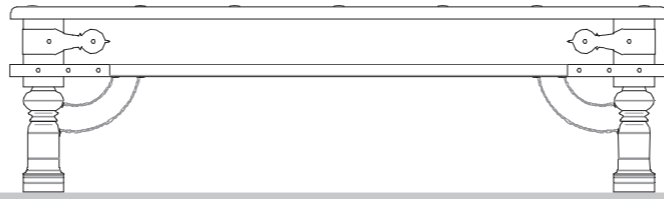

Side elevation

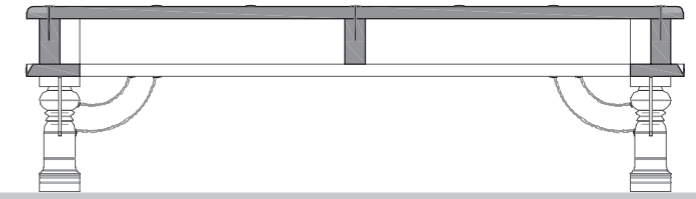

Section 1

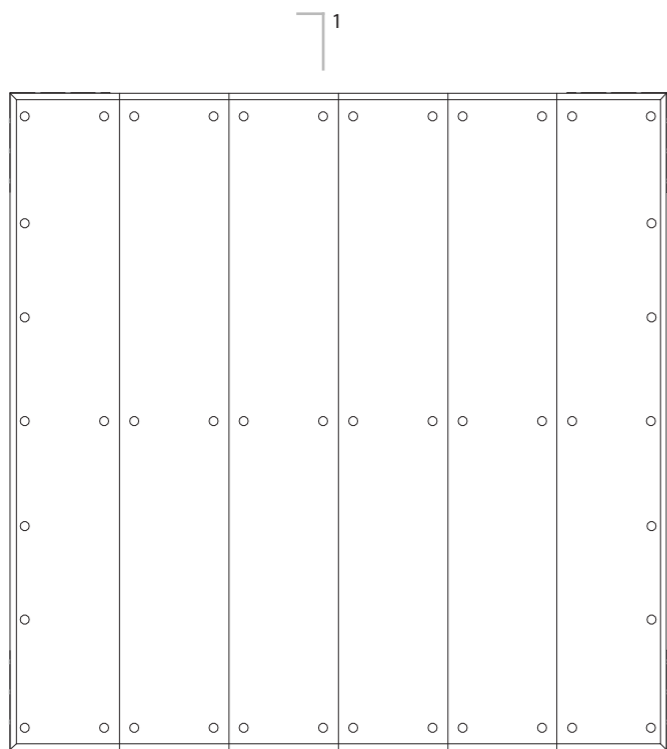

Plan (Top View)

Vernacular Furniture of Punjab

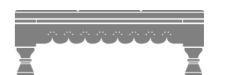

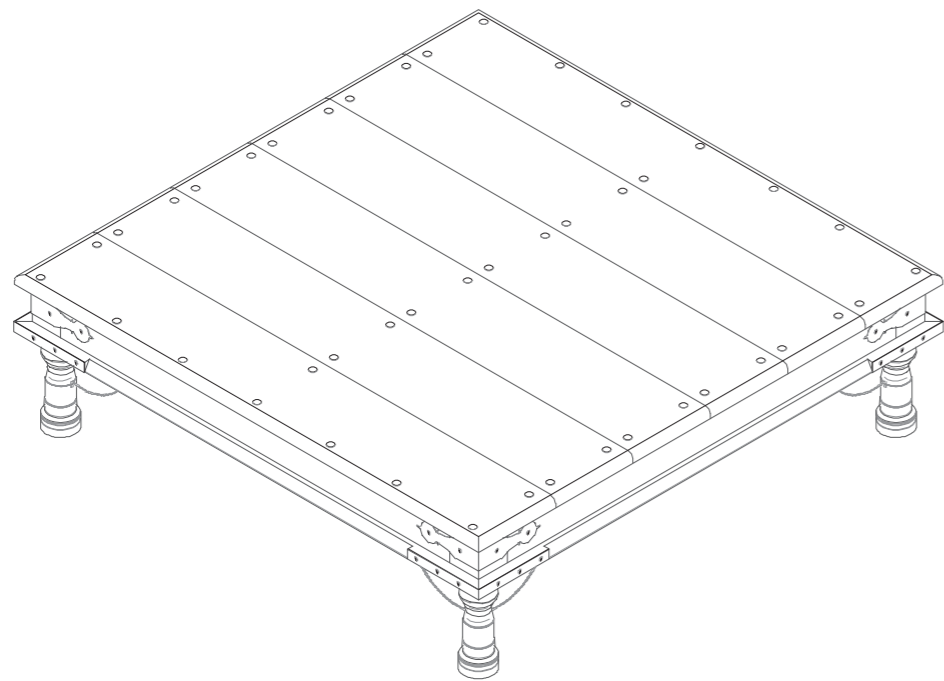

Isometric view

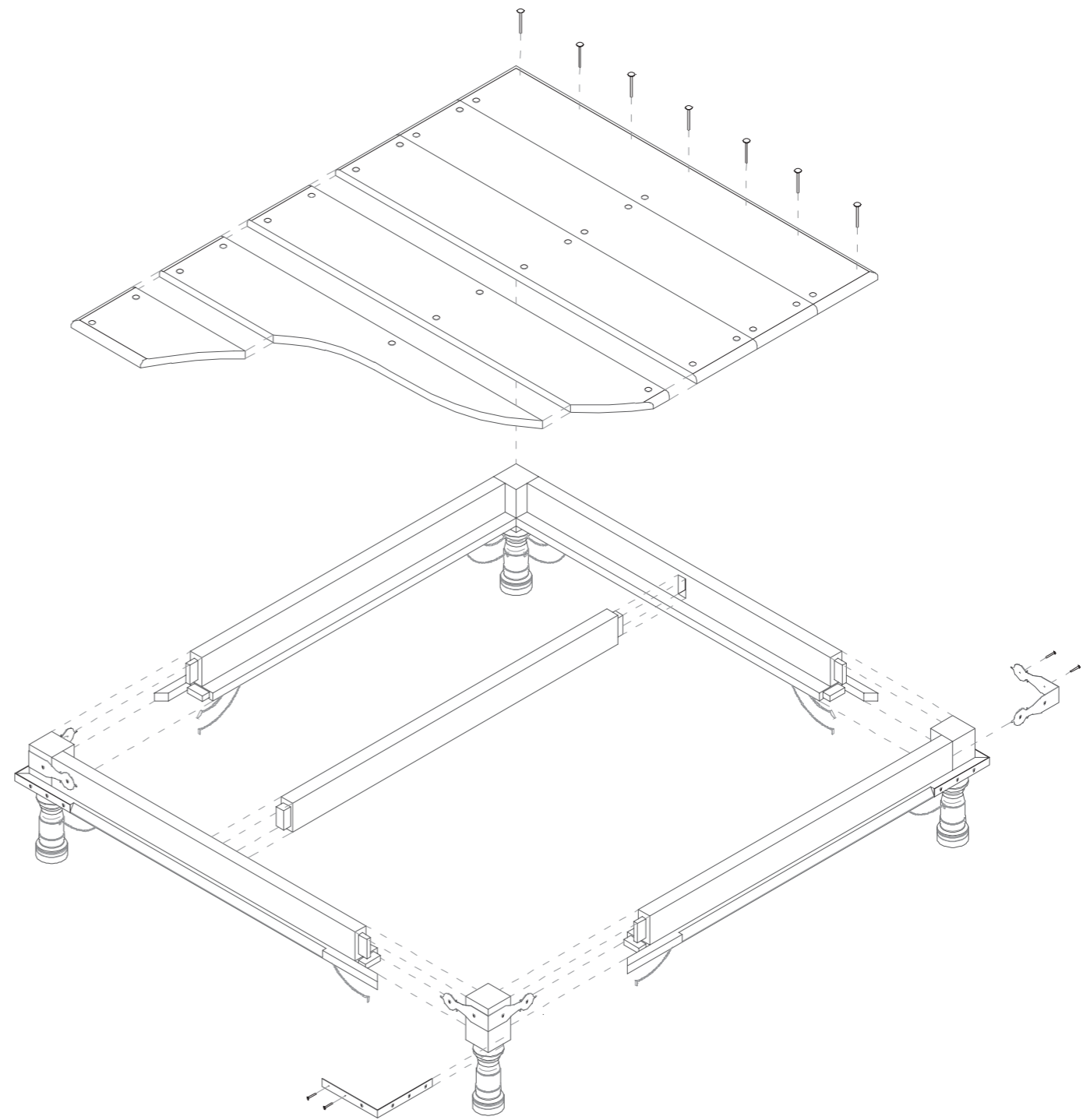

Exploded Isometric view



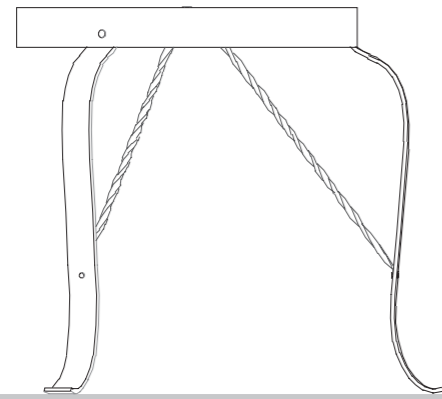

Front elevation

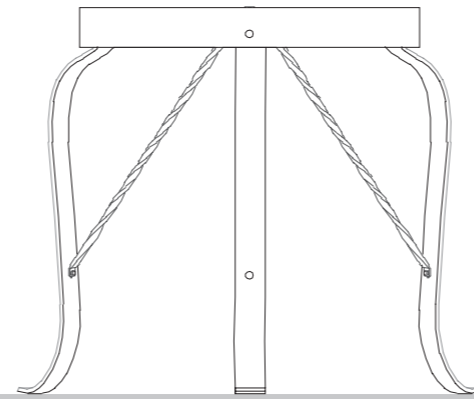

Side elevation

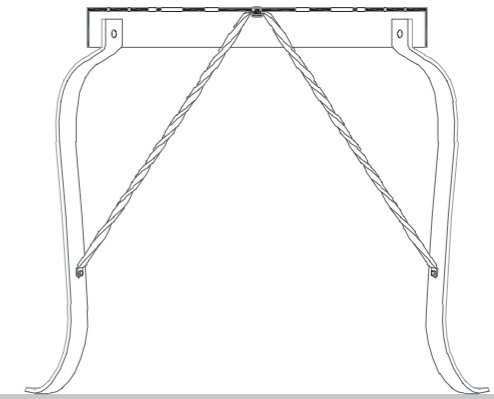

Section 1

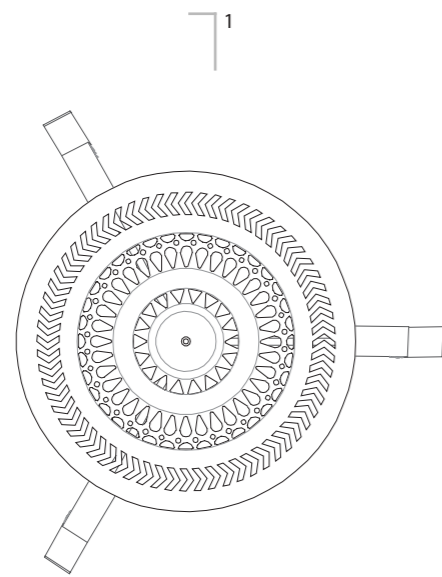

Plan (Top View)

Vernacular Furniture of Punjab



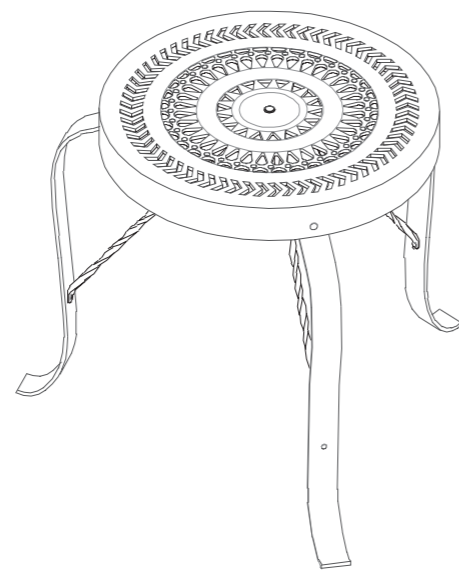

Isometric view

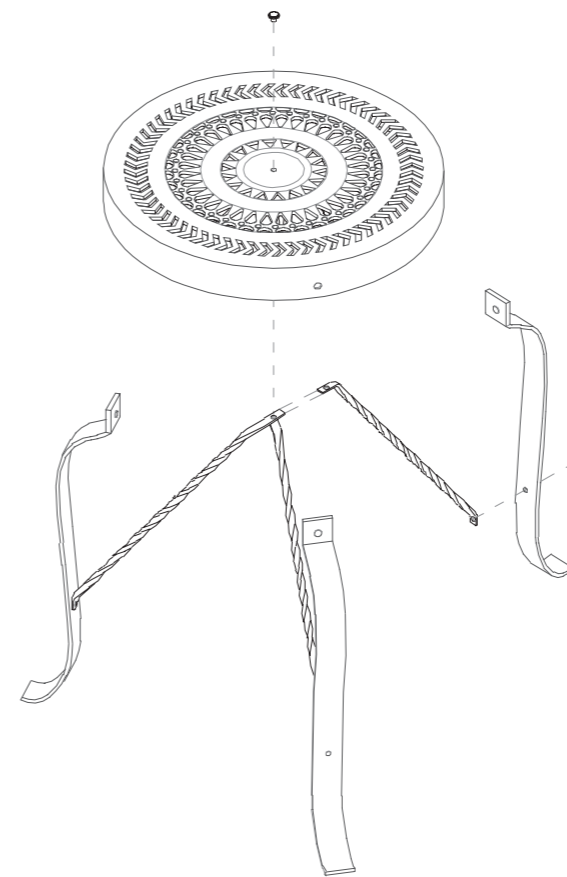

Exploded Isometric view



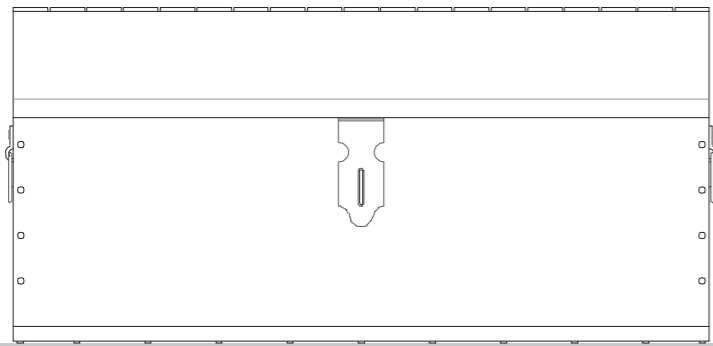

Front elevation

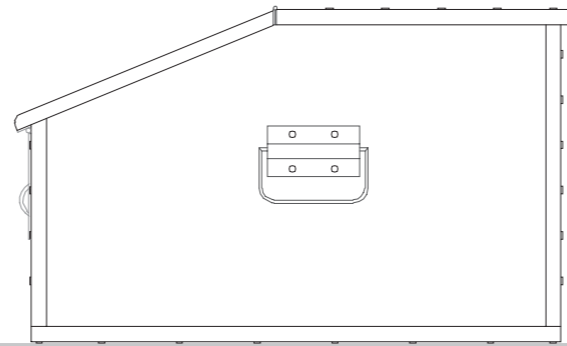

Side elevation

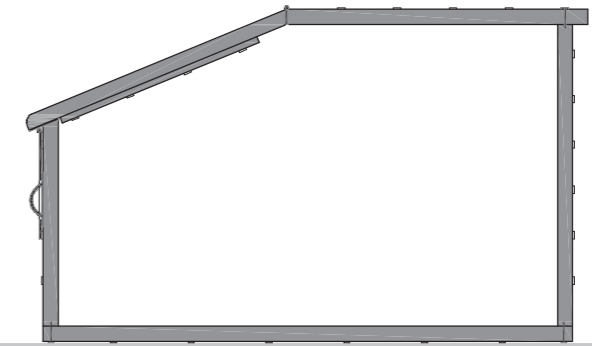

Section 1

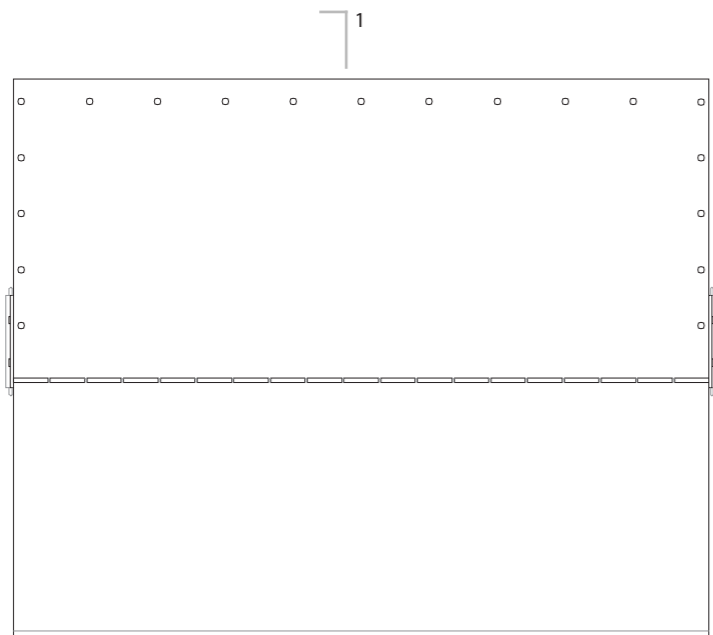

Plan (Top View)

Vernacular Furniture of Punjab



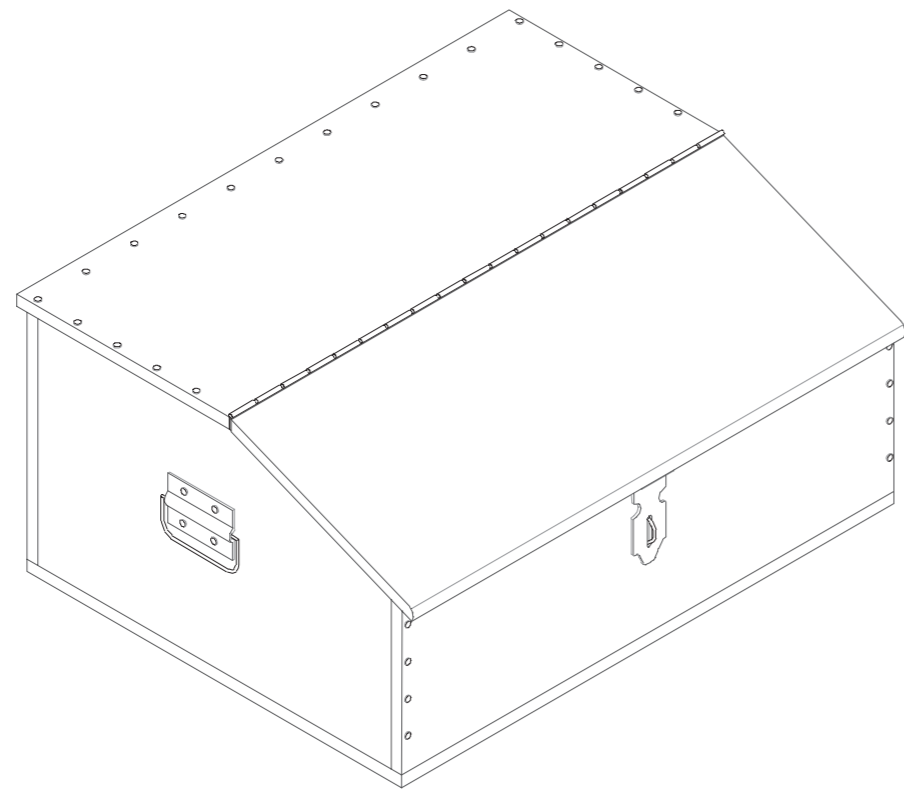

Isometric view

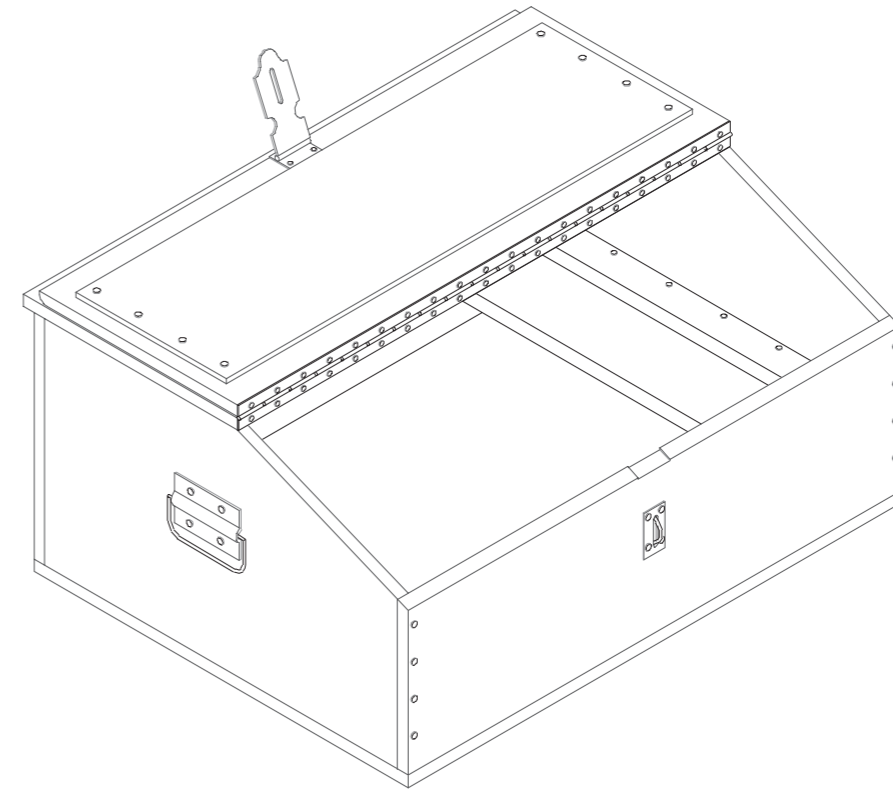

Isometric view (open)

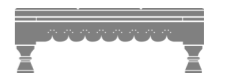

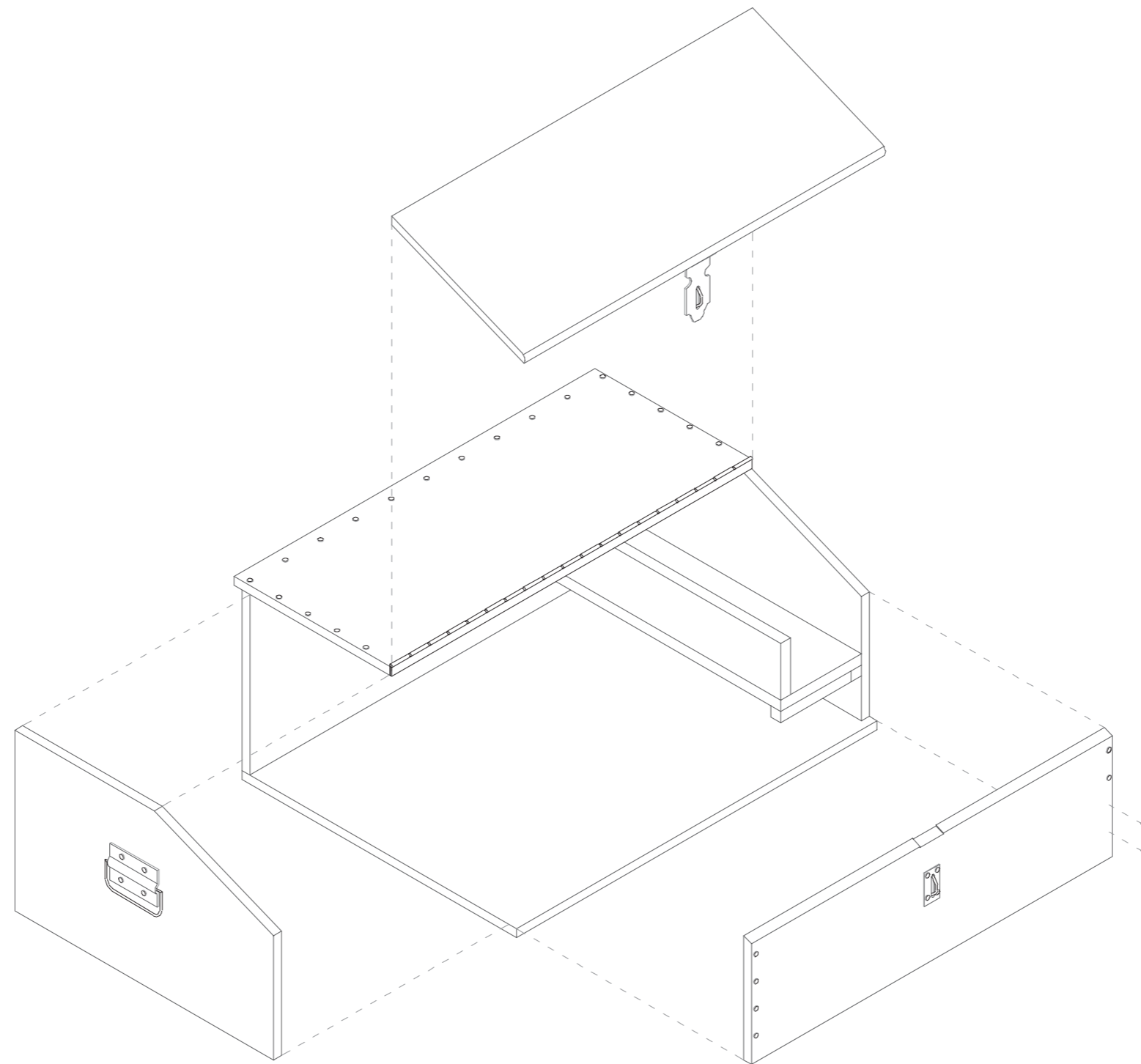

Isometric view (open)

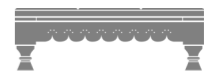

Collaborators

Design Innovation and Craft Resource Centre (DICRC) CRDF, CEPT University, India

The Design Innovation and Craft Resource Centre (DICRC), CRDF, CEPT University, India functions as a research centre for the development and understanding of the traditional and vernacular building and craft practices of India. At DICRC, crafts are studied under two primary categories: SMC (Space Making Crafts) and SNC (Surface Narrative Crafts).

DICRC's prime goal is to promote the significance of, and encourage the study of, the traditional and vernacular building and craft practices of India by means of dedicated research and innovation.

In order to do so, DICRC relies on five major focus areas: Research and Documentation (which includes mapping, documentation, research and analysis), Innovation and Development (through workshops, internship and fellowship programs), Education and Training (by means of conducting lectures, seminars and forums to establish the role of craft in Interior Architecture at national and international level), Application and Collaboration (taking up national and international collaborative research projects), and lastly, Resource Building and Dissemination (sharing the collaborators process and results of all our activities on our open source platform the Building Craft Lab [BCL]).

DICRC is a conducive platform where design thinking engages with a range of crafts and traditional knowledge. It also provides consultancy services to creative persons, artisans and the interior architecture industry for the implementation of innovative ideas in the field of crafts within current interior architecture education as well as practice. DICRC was founded by Prof. Krishna Shastri (former Director, DICRC and former Dean, Faculty of Design, CEPT University) and Jay Thakkar (Executive Director, DICRC and Associate Professor, Faculty of Design, CEPT University).

South Asian Decorative Arts & Crafts Collection Trust (SADACC), UK

The South Asian Decorative Arts and Crafts Collection Trust (SADACC) cares for and manages The South Asia Collection Museum. SADACC is a registered charity, founded in 2010. The mission of the Trust is to record, conserve and promote the arts, crafts and cultures of South Asia and neighbouring countries, including Burma, Thailand, Indonesia, Uzbekistan, Afghanistan and Iran.

SADACC cares for a collection of over 6000 objects and artworks from South Asia. This primary focus on the arts and crafts of South Asia makes The South Asia Collection Museum unique when compared to museums in both Europe and South Asia. The importance of this collection was assessed by a number of external experts when the SADACC Trust was founded.

SADACC aims to become a leading research centre for the arts and crafts of South Asia. As such, the SADACC team co-ordinate a number of research projects in South Asia and the UK.

SADACC hosts a research library, is involved in archive building, shares the collection through exhibition displays, and organises events and lectures which provide a platform for external academics, independent arts organisations and our own research. SADACC has supported postgraduate research into the arts and crafts of South Asia, provides student placements, hosts visiting research fellows, works closely with local universities, school groups, arts organisations and with local, national and international museums.

The South Asia Collection Museum (cared for and managed by the SADACC Trust) and The South Asia Collection Shop (managed by Country & Eastern) are both housed in the same building – a restored Grade II listed Victorian roller skating rink, in Norwich, UK. The museum, the SADACC Trust and Country & Eastern were founded by Philip and Jeannie Millward, who have been working in South Asia since the late 1970s.

Acknowledgements

Drawing Portfolio of Vernacular Furniture: Punjab is the outcome of an extensive survey of the vernacular furniture of Punjab. The study undertaken for the Portfolio is part of a pioneering research project titled: Vernacular Furniture of North-West India, carried out by the Design Innovation and Craft Resource Centre (DICRC), CEPT University, Ahmedabad, India, in collaboration with the South Asian Decorative Arts and Crafts Collection Trust (SADACC), Norwich, UK. Both organisations would like to acknowledge the many individuals and institutions whose contribution has led to the successful completion of this Portfolio.

While this Portfolio has been mainly prepared by a team at DICRC who have been credited at the start, we would like to express our gratitude to the rest of the team who have worked on or contributed to this project; Piyush Shah, Pooja Acharya, Anshula Prehar, Kirtan Shah. The team at SADACC have actively participated and supported the project in various capacities. We are greatly indebted to Dr Ben Cartwright, Collection Curator at The South Asia Collection is also co-author (along with Rishav Jain, Mansi S Rao and Abhishek Ruikar) on the Catalogue of Vernacular Furniture: Punjab, a main output of this project. His involvement in the project is invaluable. We are grateful to the SADACC team; Collection Manager: Hannah Bentley, Assistant Curator: Christine Blackburn, Graphics Assistants: Charlotte Reeve, Amy Fellows, Patricia Mercer-David, Collection Photography: Jake Mann, Zac Massey, Louis Pugsley Birch, IT Support: Sidney Reeve, Nick Lewers, Nahim Islam, and Sandipan Goswami.

We are particularly indebted to Krishna Shastri (Former Dean, Faculty of Design, CEPT University, and Former Coordinator, DICRC) for her constant support towards the project. We would like to acknowledge Kireet Patel (Associate Professor, Faculty of Design) for his valuable inputs on the construction drawings of the vernacular furniture. We express our thanks to Suren Vakil (Vice-Chairman), Darshan Parikh (Director), Shivangie Srivatsava (HR Manager), Sonal Trajcker (Accounts) and the team at the CEPT Research and Development Foundation (CRDF) for their administrative support, especially Anu Sutaria (Director, Alumni Office) and Pooja Sanghani (Coordinator, Alumni Office). We would also like to thank Tridip Suhrud (Professor and Director, CEPT Archives and University Press), Saumya Das (Former Coordinator, CEPT Archives and University Press), Apurva Ashar (Navjivan Press) for their support.

We are grateful to the Charles Wallace India Trust (CWIT) and the Simon Digby Memorial Charity (SDMC) for providing members of the DICRC team – Jay Thakkar (2015), Mitraja Bais (2016), Mansi S Rao (2017) and Samrudha Dixit (2018) – with research grants to visit SADACC and advance their study of vernacular furniture items and traditional architectural elements from north-west India.

Various museums and educational institutions have generously supported this research. We extend our heartfelt gratitude to the Central University of Punjab, Museum of Social History

and Rural Life of Punjab - a part of Punjab Agricultural University, Virasat a Khalsa Museum and Heritage Cell of Khalsa College, Jalandhar for sharing their collections with us and enriching our knowledge of the vernacular furniture of Punjab.

There are a number of people who have assisted our work researching the vernacular furniture at The South Asia Collection. These include the colleagues, academics, museum professionals and others who have given valuable advice, insights and those who have reviewed the written text on its journey to completion. There are too many individuals to mention them all by name, but in particular we would like to thank: Richard Alford (Former Secretary, Charles Wallace Trust), Katherine Bridges (Collections and House Officer, National Trust), Rosemary Crill (Former Senior Curator, Asian Department, Victoria & Albert Museum), Alec Cummings (artist), Brian Durrans (Former Senior Curator, Asia Department, British Museum), Mark Elliott (Senior Curator, Anthropology, Museum of Archaeology and Anthropology, University of Cambridge), Richard Everitt (Former Director, Education and Society, British Council in India), Shreela Gosh (Secretary, Charles Wallace Trust), Clare Harris (Professor for Visual Anthropology, University of Oxford, and Curator for Asian Collections, Pitt Rivers Museum), Gustav Imam (Collection Curator, Sanskriti Museum and Art Gallery), John Mack (Professor of World Art Studies, Sainsbury Research Unit, University of East Anglia and Trustee of the SADACC Trust), John Mitchell (Emeritus Professor, School of Art, Media and American Studies, University of East Anglia), Victoria Mitchell (Research Supervisor, Norwich University of the Arts), Divia Patel (Senior Curator for South Asia, Victoria & Albert Museum), Naomi Pierrepoint (Collections Volunteer), Tirthankar Roy (Professor, Department of Economic History, London School of Economics), Daniel Rycroft (Senior Lecturer in the Arts and Cultures of Asia, University of East Anglia), Deborah Swallow (Professor, The Courtauld Institute of Art, and Executive Trustee for the Nehru Trust for the Indian Collection at the Victoria and Albert Museum), the team at Country & Eastern (The South Asia Collection shop), Laura Williams (Director, Art18/21), Alexandra Woodall (formerly Head of Learning, Sainsbury Centre, University of East Anglia), Nadine Zubair (PhD Research Student, World Art Studies, University of East Anglia), Annie Woodman (Eye Film), Jason Ng (Research Assistant, Department of Architecture, National University of Singapore), Ivor Kemp (Former British Council First Secretary for Libraries and British Council Librarian, India), Urvashi Sabu (Associate Professor, University of Delhi).

During the field visits, we were lucky to meet members of the elite and merchant families of Punjab who opened the doors of their palaces and mansions and allowed us to record the vernacular furniture items within. We were also able to visit a number of private collections and warehouses who gave us another perspective on the collection and trade of vernacular furniture. Across the state, we were reliant on the kindness shown by numerous village residents who shared their knowledge and personal stories related to the vernacular furniture. We are especially grateful to those who also shared their personal stories of the migration and trauma

of the Partition and the conflict that followed. We were also fortunate to meet and learn from the craftspeople and makers of vernacular furniture. We have made the best effort to maintain a detailed record of all the people whom we approached for help whilst conducting fieldwork in Punjab. The contributors have been listed below in alphabetical order in the regions where they helped us.

Doaba

Hoshiarpur

Raju Baba, Satwant Kaur, Manohar Singh, Jasbir Kaur, Pritpal Singh Parmar, Jasbir Kaur, Ajeet Singh, Hardeep Singh, Kaala Baagh, Lashkar Singh, Roshan Singh, Gurvachan Singh, Ameer Chand Saini, Sarpanch Jaswant, Bimla Ji, Bhajan Singh, Bhagh Ram, Roshan Lal, Udham Singh Dhadwal, Vijay Kumar, Mata Malan Devi, Anupam Khosla, Karamjeet Singh, Prabha Amar, Vidya Kaur

Jalandhar

Phumbansi Ji, Phulbai Ji, Tarsenlal Ji, Manjeet Ji, Gyano Ji, Sita Devi Prehar, Cheranjilal Ji, Gurmeet Singh, Bahardur Singh, Tarlochan Singh, Kanwarjeet Singh

Kapurthala

Bakwinder Singh, Gurjeet Kaur, Amardeep Singh, Pashpal Kaur

Nawashahr

Sunita Ji, Gurdev Kaur, Santokh Ram, Satya Ji, Harbhajan Singh, Kamlesh Rani, Hans Ji, Pyaar Kaur, Kulvir Singh, Mahinder Kaur

Majha

Amritsar

Shor Singh, Deerdar Singh, Lakhninder Singh, Jagvinder Singh, Dr. Reshgun Singh, Manadi Ramandeep Kaur, Digandhar Singh, Ghurbhatt Singh, Deedar Singh, Gurwell Singh, Mannpreetji, Jagtar Singh Dhaliwal, Sadda Pind, Rupinder Ji (BBK DAV College for Women), Manpreet Ji (BBK DAV College for Women), Ajay Ji (BBK DAV College for Women), Virasat Haveli, Sukhwinder Singh (Palki Craftsperson), Vikram Singh, Beerwinder Singh, Manjit Kaur, Ghurpar Singh

Gurdaspur

Gurdeep Kaur, Surjeet Kaur, Satpal Singh, Usha Rani, Baba Kesar, Gurmeet Kaur, Joginder Kaur, Bhajani Kaur, Mohinder Kaur, Raj Kaur, Manjeet Kaur, Davinder Singh, Surjeet Singh, Jalal Maseeh, Bawa Puro, Dhanti Ji, Jacob Teja, The Punjabiyat Resort, Gurudwara Chota Ghallughara Sahib, Kundan Singh, Bhajan Singh, Ujagar Singh, Soorti Singh, Sarpanch Gurmeet Singh

Pathankot

Usha Rani, Mahinder Singh, Godu Devi, Shammo Devi, Samita Devi, Dayaal Singh, Tripta Devi, Shakuntla Devi, Balbir Singh, Kishan Singh, Mangi Sharma, Rekha Rani, Bhajan Kaur, Baawi Devi, Jakhbad Jogia Nath Mahal, Charanjeet Kaur, Chanan Singh, Kamaljeet Kaur

Tarn Taran

Bhalwinder Singh, Gurudwara Baoli Sahib, Jaiv Singh, Mehar Singh, Balraj Singh, Gurdev Singh, Lakhwinder Singh, Pratap Singh, Sukhraj Singh, Gurdev Singh, Gurudwara Manji Sahib, Amarjeet Kaur, Balwinder Kaur, Sandeep Kaur, Sukhchain Singh, Jagwant Gill, Hawaldar Balbir Singh, Sardar Budha Singh, Kar Sewa Dera Baba Jiwan Singh Ji, Narwaer Singh, Davinder Singh, Balwinder Kaur

Malwa

Ajitgarh

Gagan Gupta (Shop Owner), Charanjeet Kaur, Rana Abdulim Haveli, Jaswant Singh Lambardar, Amar Kaur, Laabh Singh, Reshma Kaur, Charno Ji, Soam Kaur, Jeeto Kaur, Amreek Singh, Bholi Kaur

Barnala

Kulwinder Singh, Gurdev Kaur, Bhadaur Singh, Ram Singh, Bhola Singh, Shaheedan Singh, Jarnail Kaur, Surjit Singh, Mithu Khan, Khushi Khan, Pritam Singh, Gurmeet Singh, Pritam Singh, Harjinder Singh, Harjinder Singh, Bhutta Singh, Amarjeet Kaur, Gurcharan Singh, Master Jagtaar Singh, Gurdev Singh Soni, Nachhattar Singh, Amarjeet Kaur

Bathinda

Baghla Furniture House, Harwans Singh Dhillon, Gurjan Singh, Sukhveer Kaur, Sukhveer Kaur, Jagdish Singh, Gurcharan Singh, Charanjeet Kaur, Hardeep Kaur, Tej Kaur, Rani Kaur, Jagdev Singh, Darshan Singh, Sukhdev Singh, Darshan Singh, Gurdev Singh, Gurtej Singh, Chota Gurusar Gurudwara, Chota Gurusar Gurudwara, Swarnajeet Singh, Balwinder Singh, Jarnail Singh, Chanan Singh, Harbans Singh, Arjan Singh, Darshan Singh, Krishan Singh, Surjeet Kaur, Sardar Balwinder Singh, Hardev Singh

Faridkot

Rustom Massey, Galmer Singh, Gurusewat Singh, Bawa Singh, Balbir Singh, Lal Chand, Surinder Dhir Haveli, Gurtej Singh, Kala Singh, Budhram Thekedaar, Kila Singh, Charan Das Sharma, Chhinderpal Kaur, Thana Singh, Guran Dutta

Fatehgarh Sahib

Sohan Singh Mankoo, Davinder Singh, Hazrat Seyfeddin Farooqi, Sukhchain Singh, Lakhwinder Singh, Mohinder Singh, Karamjeet Singh, Manjeet Kaur, Sardar Kirpal Singh, Kamaldeep Kaur, Surinder Kaur Rashpal Singh, Sukhwinder Kaur, Avtaar Singh, Sardar Harmesh Singh, Sarदार Gurmail Singh Toor, Rajinder Singh, Surjeet Kaur, Dara Singh, Kashmir Mohammad, Rajinder Singh

Fazilka

Dhyan Kaur, Sardar Rughbir Singh, Garjeet Singh, Satinder Pal Singh, Arshveer Singh, Ranveer Siyag, Krishna Lal Sihag, Balram Rinua, Raghav Sachdeva, Soni Mistry, Balbir Chand, Mahender Singh, Mangat Singh, Kuldeep Singh, Pooran Singh, Mistri Jagga Singh, Brijlal Jaiya, Tez Kaur, Kirianwala Pind, Bohar Singh, Madan Lal Bhatti, Harbhajan Lal Chatradh, Bantaram Chatradh, Jagtar Singh

Ferozepur

Sarjeet Singh, Amreek Singh, Kashmir Singh, Amreek Singh, Mukhtyar Singh, Ajit Singh, Sandeep Singh, Shri Pothimala Sahib, Resham Singh, Surjeet Kaur, Agwal Singh, Jaswant Singh, Prem Singh, Manjeet Singh, Garmeer Kaur, Karanjeet Singh, Pritam Singh, Jaswinder Singh, Dr. Mohan Singh

Ludhiana

Sukhpal Kaur, Praveen Kaur, Sukhvinder Kaur, Pyaro Bai, Museum of Social History and Rural Life of Punjab - Punjab Agricultural University, Paramjeet Kaur, Pyara Singh, Sukhdev Singh

Mansa

Vijay Kumar Samariya, Purana Bazaar, Ashok Kumar, Raj Kumar Haveli, Vijay Kumar Samariya, Des Raj Singh, Babu Ram, Kuldeep Tailor, Malkeet Singh, Tarsen Singh, Dashmi Paatshahi Gurudwara, Kuldeep Singh, Hoshiyaar Singh, Bagicha Singh, Karnail Singh, Gurdeep Singh, Kripal Singh, Balwant Singh, Hardeep Singh, Kamal Kaur, Jagpal Singh, Lakhwinder Singh, Satnam Singh, Sohan Singh, Roshi Singh, Karamat Sahib Gurudwara, Balwant Singh, Kaka Singh, Mithu Singh, Gurpreem Singh, Hardev Singh, Channa Ramji, Jeevan Singh, Darshan Singh, Balwinder Kaur, Pyaara Singh Sohi, Karniyal Singh, Gurjeet Singh, Baldev Singh, Gurnaam Kaur

Moga

Jagsir Singh, Bikkar Singh, Baldeep Singh, Darshan Singh, Paramjeet Singh, Kulbir Singh, Basant Kaur, Charanjeet, Jagdev Singh, Sukhdev Singh

Patiala

Jasveer Ram, Hukum Chand, Jasbir Singh, Jasmer Singh, Manjeet Kaur, L.D. Gupta, Punjab

Emporium, Patiala City, Sukhwinder Singh, Mr. Hardeep Singh (Tourist Information Centre), Shyamlal Jain, Jagannath Jain, Mehar Singh, Karam Singh, Jaswinder Kaur, Tejinder Pal Singh, Gulbaag Singh, Ram Nath, Bahadur Singh, Gurdeep Singh

Rupnagar

Sukhdev Singh, Sikandar Singh, Jagdev Singh, Surjit Kaur, Balwinder Singh, Davinder Singh, Ajmer Singh, Darshan Singh, Maghar Singh, Bachani Devi, Yashpal Sharma, Kamala Devi

Sangrur

Balkar Hans, Prem Singh, Dr. Mohd. Rafi, Dharamjeet Singh, Modan Singh, Sewa Singh Wood Works, Dhanna Singh, Rehmat Qawal House, Rana Muhammad Ali Khan, Master Tara

Sri Mukhtsar Sahib

Sardar Balraj Singh, Sardar Gurnaam Singh, Sukhraj Singh, Angrez Kaur, Pratap Singh, Naseeb Kaur, Mukhtyar Singh, Jaginder Kaur, Harjinder Kaur, Ramandeep Kaur, Sadagar Singh, Baljinder Singh, Gurtez Singh, Chur Singh, Hardeep Singh, Prithvi Singh, Motiram Ji, Surjeet Singh, Ajmer Singh, Baljit Singh, Bhutta Singh, Nichattar Singh, Sukhminder Singh, Kulwant Kaur, Lakshman Singh, Mehar Singh, Balwinder Singh, Teja Singh, Jagbir Singh, Sukhdev Kaur, Preetam Kaur, Shinder Kaur, Mohinder Kaur

We are indebted to the wonderful people of Rajasthan for the warm hospitality they extended to our team during fieldwork. In case we have missed out any names, we would like to add here that we extend our sincere gratitude to all those who have contributed to this publication.

Finally, we would like to thank the family members and friends whose support has been crucial to this project.

Drawing Portfolio of Vernacular Furniture: Punjab is a collection of technical drawings of 33 vernacular furniture pieces from Punjab. It is one of the outputs of the project, 'Vernacular Furniture of North-West India'. The project uses three main mediums to represent the findings of the research - text, photographs and drawings. The text and photographs provide an insight into anthropological aspects such as location, community, landscape and the social roles of the vernacular furniture pieces in their everyday or ceremonial contexts. Drawings on the other hand act as a tool to understand the structural complexity and dexterity of making of vernacular furniture.

